

Bio Smart Technologies, Inc

BioSmart™ Far Infrared Heat by BioSmart Technologies. *Feel the Difference.*



BioSmart™ Owner's Manual

Therapeutic infrared heating systems for a green, healthy environment

Flush Mounting Series

Model BIO-1000F/120v / Model BIO-500F/120v



Save these instructions

Includes:

- Application Guidelines
- Installation Guidelines
- User Information & Guidelines
- Operating Instructions
- Warranty & Servicing

Notice: This unit requires a conventional low-voltage thermostat to be supplied by the customer.

A low voltage thermostat, such as a Honeywell Model CT8775, or RTH5100, or equivalent must be installed in conjunction with this unit.



BioSmart™ Ceramic Infrared In-Wall Heater
BIO-1000F/120V
(Flush Mounting)

Table of Contents

Why Use BioSmart™ Infrared Heat	3
Comfort Levels & Therapeutic Benefits	3
Energy Saving Benefits	4
Unpacking Your New BioSmart™ Heater	7
Installation Guidelines	7
How Many Units do I Need?	7
Installation Instructions	8
Wiring/Thermostat Instructions & Diagram	13
For Your Safety/Warning	15
For Best Performance	15
Operating Instructions	15
Maintenance	15
Troubleshooting	16
BioSmart™ Heater Specifications—BIO-1000F/120v	17
BioSmart™ Heater Specifications—BIO-500F/120v	18
Diagram of BioSmart™ Heater BIO-1000F/120v	19
Diagram of BioSmart™ Heater BIO-500F/120v	20
Warranty & Service Information	21

Why Use BioSmart™ Infrared Heating

What Is Infrared Heat & How does it work?

Infrared heat, by virtue of its shorter wave length, is able to penetrate solid objects faster than radiant heat. The advantages of infrared heat have been utilized for years as a therapeutic treatment for cardiovascular and general circulation problems.

Comfort Levels & Therapeutic Benefits of Infrared Heat

BioSmart™ heats the room evenly from floor to ceiling. Homes and Offices with high ceilings are not affected by the difference in heat displacement between the floor and ceiling. In other words, the temperature on the floor and the ceiling remains the same without any supplemental fan circulation to keep the temperature balanced throughout the room.

The comfort levels achieved when using infrared heat are superior to those of radiant heating systems. Infrared heat *warms the body* faster so the energy that flows into the body is greater than when being absorbed from conventional radiant heating sources. Room temperatures of 68°F with infrared feel like 72°F with conventional heating sources so you can set the thermostat back 4-5 degrees and experience the same comfort levels utilizing less energy to keep you warm and cozy.

BioSmart™ heating systems are the ultimate in green technology engineering – *affordable to purchase and economical to operate* – exceptionally economical, extremely quiet, they produce comfortable, healthy, therapeutic infrared heat. They are easy to install, and they look great on your wall. BioSmart™ heating systems sterilize the air that is processed through them making them a sanitary source of heat for those suffering from respiratory conditions.

With the intent of economizing and saving on building costs, most contractors will combine the heat & air conditioning ducts into one distribution system. This makes the cross-contamination issue though the air conditioning ducts a potential health problem, especially for those with respiratory sensitivities and allergies, including asthma.

The nature of the infrared wave is such that it requires localized generation of the infrared wave in order to *optimize the efficiency and savings* produced by using an infrared heating source. This design advantage *eliminates the need*

for ductwork to distribute the heat through the various rooms of a home or office. Eliminating the ductwork also *eliminates the dust pollen and mold* that accumulates in a conventional heat duct system.

Energy Saving Benefits

Infrared heat waves are transferred more quickly throughout the room due to their shorter wave length. The results are impressive because it requires less energy to heat the room evenly with infrared heat than with radiant heating sources. This makes infrared heat a highly cost-efficient solution for heating your home.

If you really want to *save on energy costs*, the cost of heating with BioSmart™ heat is going to be spectacular. Usually a 50% savings over conventional heat sources is achieved, even with other electrically generated heating systems. As much as 65% savings is achieved if replacing heating oil or other fossil fuel heating systems.

Quiet Operation

BioSmart™ heating systems operate virtually silently at over 150 cubic feet per minute per heating unit. They are quieter than forced air systems and they do not have the typical cracking and popping experienced when heating with baseboard heaters. Compared to conventional in-wall heaters there is no comparison to the quiet operation of the BioSmart™ fan system. Fans are rated at 16 dB compared to 65 dB of conventional in-wall heating systems.

Better Heat Distribution

The nature of the infrared wave allows the heater to be installed higher on the wall than conventional in-wall heater systems without compromising the transfer of the heat to the floor. The advantage of the higher installation on the wall guarantees that furniture and other obstructions to the airflow from the heater are eliminated. **Child tampering is also eliminated.**

Even distribution of the infrared wave is also assured since the air space above the furniture is virtually unrestricted. When conventional heat sources are vented through the ceiling to economics and save on construction costs, the heat remains on the ceiling and must be pushed to floor with ceiling fans. This is not required with infrared heat.

Accurate Temperature Regulation

The BioSmart™ heating system utilizes state of the art electronics and internal power sourcing to accept a low-voltage thermostat of your choosing. Low voltage wall thermostats provide more accurate temperature control and can be linked to a central control system if desired.

The unique low-voltage thermostat controls on a BioSmart™ heater allow the heater to be linked to a central zoned control system without modification or special switching devices to control the voltage to the heating elements themselves. This feature allows the BioSmart™ system to be operated in the most economical manner possible by utilizing the infrared heat only in those spaces which are currently being occupied and require the heat. Zoned heating is as much as 50% more economical to use when the entire home or office does not require heat in all areas 100% of the time. The cost savings from this feature alone makes initial installation of the BioSmart™ heating system pay for itself in a matter of months.

Cost-Effective to Install

* Components in the BioSmart™ heating system are designed to last 10 times longer than other in-wall heaters. BioSmart™ warranty coverage and service procedures are simple to follow and they can be serviced in ten minutes or less should repair be required.

* The cost to purchase and install a BioSmart™ infrared heating system for your entire home is usually much cheaper than the cost of installing a central forced air heating system.

Stylish & Functional

The BioSmart™ heater service panel and wall registers are stylish and functional with a modest design flare making them more favorable for custom-home installation than conventional registers and intake ducts. The designer panel on the wall register can be left white or custom painted to match or contrast the walls.

Patented Proprietary Technology

BioSmart™ heaters contain a proprietary high-efficiency, ceramic infrared emitter (or heating element) which produces more infrared heat per kilowatt than conventional ceramic, quartz, or carbon plates.

Patent pending coverage of more than 30 distinct features in the BioSmart™ heater are what makes the BioSmart™ technology a truly unique energy efficient heat source for your home or office.

Flexible Size & Voltage Applications

BioSmart™ heating systems come in 120 volt units for new construction. The 120 volt units are designed to be retrofitted to existing installations where only 120 volt circuitry is available.

BioSmart™ heaters come in two sizes: 1000 watts for conventional room heating and 500 watts for bathrooms, hallways and closets.



BIO-1000F/120V - 1000 watts



BIO-500F/120V - 500 watts

Quality Assurance

BioSmart™ heating systems come with C-TUV-US certifications with equivalent approvals both in UL and CSA classifications. BioSmart™ heaters are manufactured in Taiwan and China by TrueGreen Electronics, Inc.

Unpacking Your New BioSmart™ Heater

1. FIRST, inspect the package for any obvious damage.
 2. Remove the protective packaging materials from the outside of the heater cabinet and from the front face panel.
 3. Remove the protective packaging materials from the **inside** of the heater's heat exchanger, making sure that all combustible materials have been removed from around the black ceramic heating elements.
 4. Inspect the unit to make sure that there are no crack in the black ceramic heating elements.
 5. If no obvious damage is visible, proceed with the installation instructions as outline in the Installation Guidelines included with this manual.
-

Installation Guidelines

How Many Units Do I Need?

When determining the right number of units to install in a conventional home, the following items need to be taken into consideration:

- The insulation factor, and window size & placement
- The mean outside temperature during the coldest days of the year
- The size of each room
- The overall size of the home
- The number of floors involved
- The Entrance and Egress points

In lieu of overall engineering calculations and thermal loss calculations, a general rule of thumb can be applied to determine the number of units to be installed:

Notes: Calculate 4-6 hours of running time per day per heater installed to calculate Btu's and electrical energy cost. Also, remember that multiple unit installations in larger rooms can be coupled to the same low-voltage thermostat or regulated separately.

**New construction (coldest day above 5 degrees),
standard insulation, one window per room:**

Room size below 250 sq. feet: 1 - 1000 watt unit

Room size above 250+ to 500 sq. feet: 2 - 1000 watt units

Room size above 500+ to 750 sq. feet: 3 - 1000 watt units

Room size above 750+ to 1000 sq. feet: 4 - 1000 watt units

Room size above 1000+ to 1250 sq. feet: 5 - 1000 watt units

**New construction (coldest day below 5 degrees)
& all remodels, standard insulation:**

Room size below 200 sq. feet: 1 - 1000 watt unit

Room size above 200+ to 400 sq. feet: 2 - 1000 watt units

Room size above 400+ to 600 sq. feet: 3 - 1000 watt units

Room size above 600+ to 800 sq. feet: 4 - 1000 watt units

Room size above 800+ to 1000 sq. feet: 5 - 1000 watt units

Room size above 1000+ to 1200 sq. feet: 6 - 1000 watt units

Hallways and Nooks: 1 - 500 watt unit per 100 sq. feet

Closets and Bathrooms: 1 - 500 watt unit per 100 sq. feet

Installation Instructions for 1000 watt unit

Required outlet opening: The heater cut-out must have a minimal size of 12.75 in. W x 15.5 in. H x 3.5 in. D in order to accommodate the heater.

Mounting the Heater

The heater comes with two sets of mounting brackets. Using the appropriate set of brackets for the mounting conditions, attach the heater unit to the wall preferably 6 ft. above the floor to eliminate obstructions to air flow. The heater can be mounted lower if preferred. The higher location of the heater also insures that obstacles in the room such as furniture will not encumber the circulation of the infrared heat waves being generated from the heater. This assures even heat distribution and prevents cold-pockets of air. The infrared heat will flow evenly from floor to ceiling so the location of the heater on the wall is not pre-empted by normal in-wall heater considerations.

Note: Each BioSmart™ heater comes with two sets of mounting brackets. One set is for mounting the unit prior to sheet rock installation, and the second set is for mounting the unit after sheetrock installation, as in the case of a remodel.

Mounting Guidelines (*BIO-1000F/120v*)

BIO-1000F/120v New Construction Installation

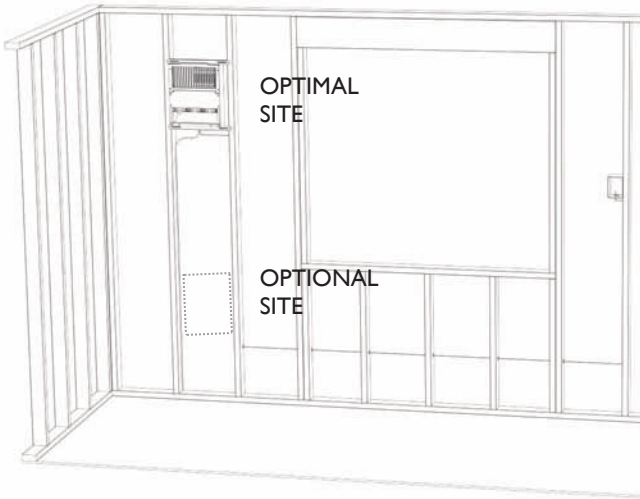

Heater must not be located immediately below a socket-outlet.

Use the following mounting brackets for heater installation prior to sheetrock installation.

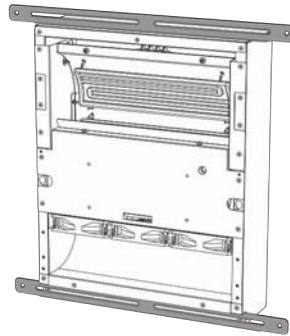

Use the new construction brackets as shown. Attach the heater unit to the wall, 6 ft. (1.8 m) or higher above the floor to the bottom of the heater unit. The higher the better. The higher location of the heater insures that obstacles in the room such as furniture will not encumber the circulation of the infrared heat waves being generated from the heater. This assures even heat distribution and prevents cold-pockets of air.

Customer/Warranty Service: (800) 595-9605

Mounting Guidelines (*BIO-1000F/120v*)

BIO-1000F/120v Existing Construction Installation

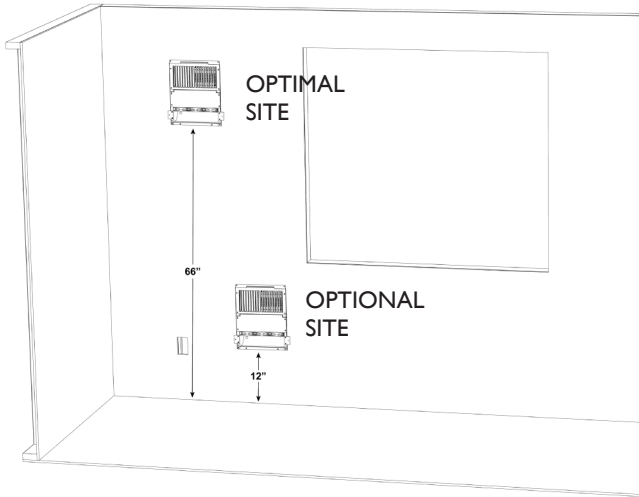

The heater cutout should have a minimal size of $15\frac{1}{2}$ (h) x $12\frac{3}{4}$ (w).

Use the following mounting brackets for heater installation in existing construction.

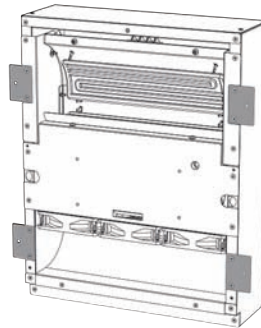

Use the retrofit brackets as shown. Attach the heater unit to the wall, 6 ft. (1.8 m) or higher above the floor to the bottom of the heater unit. The higher the better. The higher location of the heater insures that obstacles in the room such as furniture will not encumber the circulation of the infrared heat waves being generated from the heater. This assures even heat distribution and prevents cold-pockets of air.

Mounting Guidelines (*BIO-500F/120v*)

BIO-500F/120v New Construction Installation

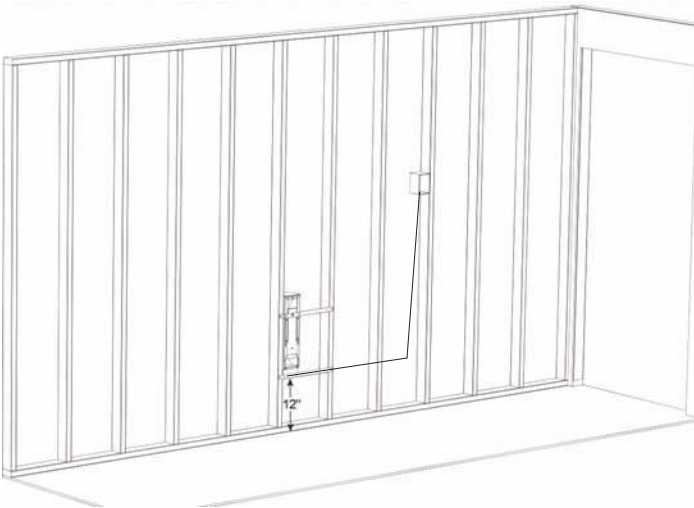

Heater must not be located immediately below a socket-outlet. The heater is to be installed so that switches and other controls cannot be touched by a person in the bath or shower.

Use the following mounting brackets for heater installation prior to sheetrock installation.

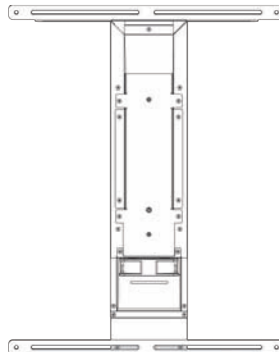

Use the new construction brackets as shown. Attach the heater unit to the wall, 6 ft. (1.8 m) or higher above the floor to the bottom of the heater unit. The higher the better. The higher location of the heater insures that obstacles in the room such as furniture will not encumber the circulation of the infrared heat waves being generated from the heater. This assures even heat distribution and prevents cold-pockets of air.

Customer/Warranty Service: (800) 595-9605

Mounting Guidelines (*BIO-500F/120v*)

BIO-500F/120v Existing Construction Installation

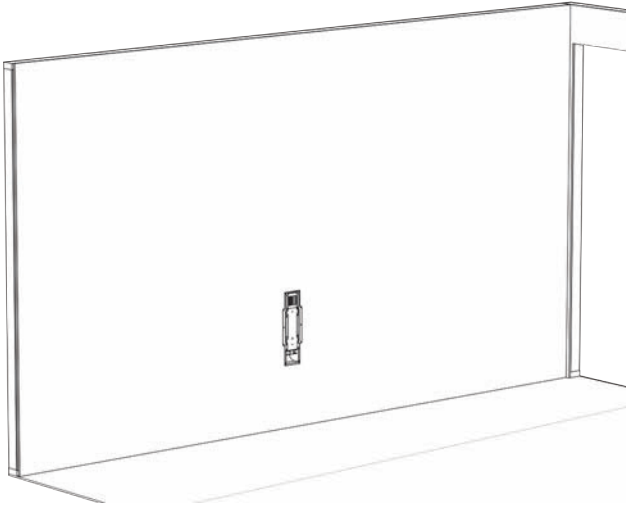

The heater cutout should have a minimal size of $18 \frac{1}{2}$ (h) x $4 \frac{7}{8}$ (w).

Use the following mounting brackets for heater installation in existing construction.



Use the retrofit brackets as shown. Attach the heater unit to the wall, 6 ft. (1.8 m) or higher above the floor to the bottom of the heater unit. The higher the better. The higher location of the heater insures that obstacles in the room such as furniture will not encumber the circulation of the infrared heat waves being generated from the heater. This assures even heat distribution and prevents cold-pockets of air.

Installation Guidelines *(continued)*

Heater Wiring

Regardless of the model chosen, there are 5 wires inside the base of the heater which must be wired correctly. Three wire contacts are required to obtain the power source. The wiring code is the same for 120 volt units.

The heater must be provided disconnect device (switch/breaker) from the supply mains having a contact separation in all poles that provide full disconnection with a contact separation of at least 3 mm.

On the large in-wall unit the black is hot, the red is neutral, and the green is ground. On the small in-wall unit the black is hot, the blue is neutral and the green is ground. On both units the yellow and white wires go directly to the thermostat.

No external power supply is needed. Any attempt to attach an external power supply will cause damage to the internal components and will result in product failure.

When connecting multiple units to a single thermostat, the units must be connected in parallel with all yellow and all white wire leads connected to their same respective terminals on the thermostat.

Failure to follow these guidelines will result in internal transformer failure and product failure.

The figures below depict a typical wiring procedure using conventional 12/2 wire on a large heater.

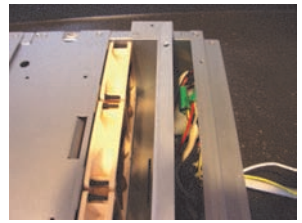

Thermostat Wiring

Use any conventional thermostat or doorbell wire to route the thermostat to the heater. Unless the thermostat is diode protected or voltage sensitive to DC (positive and negative), it doesn't matter which heater thermostat wire goes to the respective contacts on the back of thermostat.

Consult the wiring instructions that are included with the thermostat to make sure that the low voltage thermostat being used is compatible with the 12 volt DC voltage originating from the yellow and white thermostat wires from the heater. The thermostat should be located at least 5 feet from the location of the in-wall heater.

Customer/Warranty Service: (800) 595-9605

Wiring Diagrams

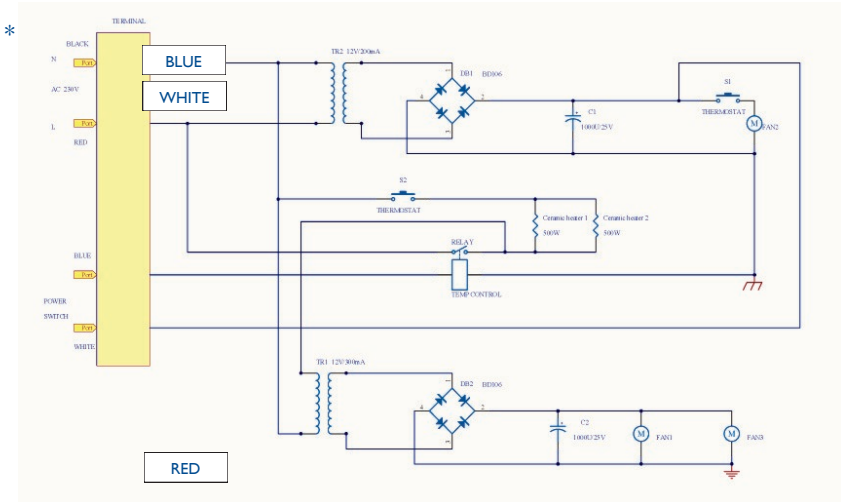

BIO-1000F/120v Wiring Schematic

* Switch must be having a contact separation in all poles that provide full disconnection with a contact separation of at least 3 mm and rated 10A minimum.

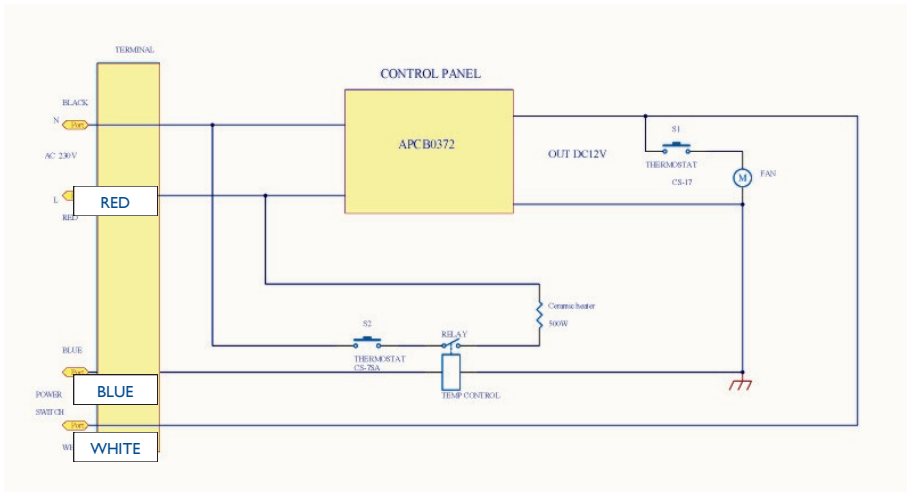

BIO-500F/120v Wiring Schematic

For Your Safety/Warning

Do not place objects in front of infrared wall units that have been mounted lower than those parameters suggested in the installation instructions. Doing so will cause the unit to overheat, which will trigger the high temperature limit switch, resulting in a potential service call to reset/replace the switch.

For Best Performance

It is recommended that the air flow pattern in the room becomes circular. This is accomplished by mounting the heater to one side of the room, as per the illustration, in order to create a circular flow around the room.

Where multiple units are installed in larger rooms, this circular pattern can be maintained by positioning the units to complement the air flows. This is accomplished by positioning them in opposite corners of the room.

Operating Instructions

The units are self-regulating. Temperature is controlled via a low-voltage thermostat located preferably on the opposite wall from the heating unit. The heater fans will turn on when the power to the infrared heating elements turn on. After the heating elements have come up to full temperature, a third fan will turn on to increase the airflow into the room. This third fan will remain running even after the heating elements have been shut down by the thermostat, in order to distribute the remaining heat in the heating elements into the room.

Temperatures can be regulated from a central control (sold separately) or the heating units can also be independently turn on or off from a remote location via a central on/off switch for each unit. The switch is connected between the low-voltage thermostat control and one of the lead wires to the thermostat from the thermostat contact on the heater.

Maintenance

Routinely inspect the air registers on the infrared unit to make sure that there is no dust accumulation. Vacuum as you would any conventional heat or air conditioning duct.

It is suggested that an annual dusting of the ceramic plates be performed in order to eliminate any residual accumulation of dust during the summer months. Other than this, there are no maintenance requirements involved. In order to accomplish this, the front plastic panel must be removed by removing the four screws and lifting up to release the panel from the top clip.

Troubleshooting Your BioSmart™

Problem

Solution

Heater is noisy

Check for obstructions to the fan blades. If there are none, you have a defective fan and must first isolate the defective fan unit for replacement. Call a service technician for installation.

Heater won't turn on

First, push the reset button. Next, check the thermostat leads. Short the leads out and if the heater turns on you have a defective thermostat, otherwise you have a defective relay in the heater. Call a service technician for installation of a new relay.

Heater fan remains running after 20 minutes of shut-down

Most likely you have a defective fan relay. Call a service technician for installation.

Heater doesn't appear to be getting hot enough

Most likely one of the ceramic elements is burnt out or the connection to the element is bad. Call a service technician to determine the cause of the problem and if necessary replace the defective ceramic plate.

Heater does not heat-up

First, push the reset button. Next, check the thermostat leads & listen to determine if the first fan is operating. If so, call a service technician for installation of a new heat relay.

BioSmart™ Heater Specifications

Model BIO-1000F/120v

- **Cabinet:** All Metal –22 & 24 gauge
- **Weight:** 13.0 lbs
- **Dimensions:** 16" x 12 5/8" x 4" (H,W,D)
- **Power Requirements:** 120 Volt AC —1000 Watt.
- **Power Supply:** Requires isolated 12 gauge wire to fuse panel.
- **Chassis Safety Insulation:** Exceeds all government and independent laboratory standards for safety in an installed heating appliance (a safety standard that exceeds other manufacturer's specifications).
- Internal ceramic blanket provides R45 insulation between the wall and the heater. The heater cabinet installed in the wall remains cool to the touch while delivering warm (160° F) infrared heat into the room.
- **Life Expectancy:** BioSmart heaters—25 years+.
- **Thermostat Power Requirement:** None. The unit contains its own low voltage power supply for thermostat operation.
- **Thermostat Type:** Any 12-24 volt low-voltage thermostat (not supplied).
- **Zoned Heat Capability:** Pre-wired. Simple two-wire contact to any zone control panel—can also accept multiple parallel hook-ups to a single low-voltage thermostat.
- **Safety Cut-Off:** Yes.
- **Listed Approvals:** CTUV-US & International (UL Equivalent).
- **Installation:** Any wall with a minimum 3 1/2 inches of depth.
- **Heat Type:** Therapeutic far-infrared heat.
- Heat Chamber copper lined for maximum ion transfer.
- **Heating Elements:** Two (2) ceramic infrared emitters 500 w., 500 w.
- **Ceramic Life Expectancy:** Rated at 40,000 hours.
- **Heat Output:** 4,800 BTU infrared heat.
- **Fan System:** Three (3) high volume, low noise 90mm DC fans.
- **Frequency Hum:** There is no AC 60Hz frequency hum as with other in-wall systems.
- **Fan Noise Level:** 18 dB—practically silent.
- **Warranty:** 3 Year P & L. 5 Year—ceramic emitters.



BIO-1000F/120v

Customer/Warranty Service: (800) 595-9605

BioSmart™ Heater Specifications

Model BIO-500F/120v

- **Cabinet:** All Metal –22 & 24 gauge
- **Weight:** 8.0 lbs
- **Dimensions:** 20 ½" x 4 ¾" x 4" (H,W,D)
- **Power Requirements:** 120 Volt AC —500 Watt.
- **Power Supply:** Requires isolated 12 gauge wire to fuse panel.
- **Chassis Safety Insulation:** Exceeds all government and independent laboratory standards for safety in an installed heating appliance (a safety standard that exceeds other manufacturer's specifications).
- Internal ceramic blanket provides R45 insulation between the wall and the heater. The heater cabinet installed in the wall remains cool to the touch while delivering warm (160° F) infrared heat into the room.
- **Life Expectancy:** BioSmart heaters—25 years+.
- **Thermostat Power Requirement:** None. The unit contains its own low voltage power supply for thermostat operation.
- **Thermostat Type:** Any 12-24 volt low-voltage thermostat (not supplied).
- **Zoned Heat Capability:** Pre-wired. Simple two-wire contact to any zone control panel—can also accept multiple parallel hook-ups to a single low-voltage thermostat.
- **Safety Cut-Off:** Yes.
- **Listed Approvals:** CTUV-US & International (UL Equivalent).
- **Installation:** Any wall with a minimum 3 ½ inches of depth.
- **Heat Type:** Therapeutic far-infrared heat.
- Heat Chamber copper lined for maximum ion transfer.
- **Heating Elements:** One (1) ceramic infrared emitter 500 w.
- **Ceramic Life Expectancy:** Rated at 40,000 hours.
- **Heat Output:** 2,800 BTU infrared heat.
- **Fan System:** One (1) high volume, low noise 90mm DC fan.
- **Frequency Hum:** There is no AC 60Hz frequency hum as with other in-wall systems.
- **Fan Noise Level:** 18 dB—practically silent.
- **Warranty:** 3 Year P & L. 5 Year—ceramic emitters.



BIO-500F/120v

Diagram of BioSmart™ Heater BIO-1000F/120v

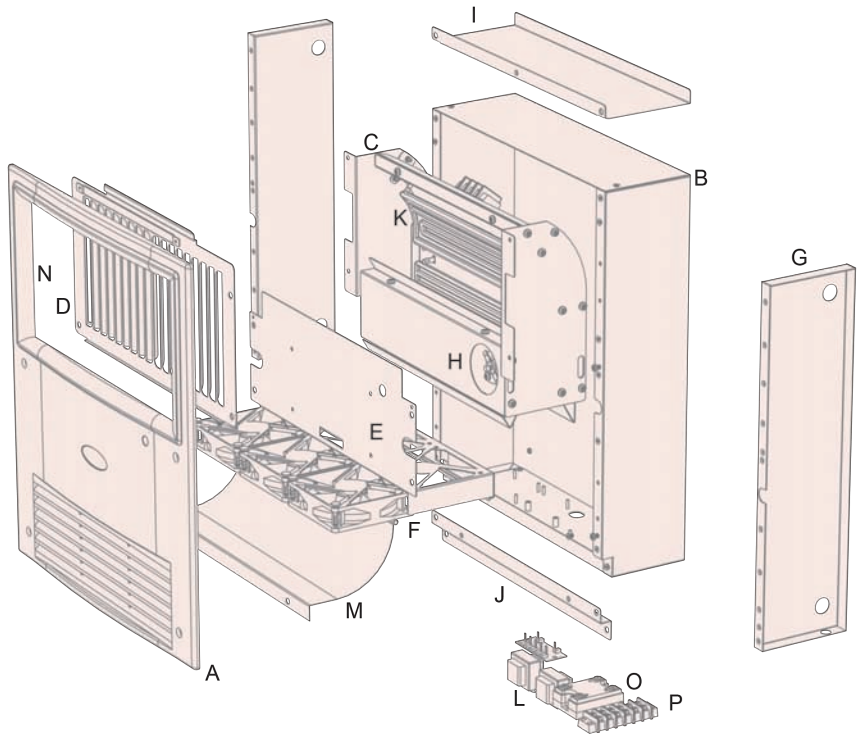

Parts List

A	Cover	J	Bottom Case Bracket
B	Case	K	Ceramic Heating Element
C	Heater Core	L	Fan Transformer
D	Grill	M	Baffle
E	Fan Holder	N	Heat Resistant Insert
F	Fans	O	Solid state relay
G	Insulator Cover	P	Connection Plate
H	High Limit Reset		
I	Top Case Bracket		

Diagram of BioSmart™ Heater BIO-500F/120v

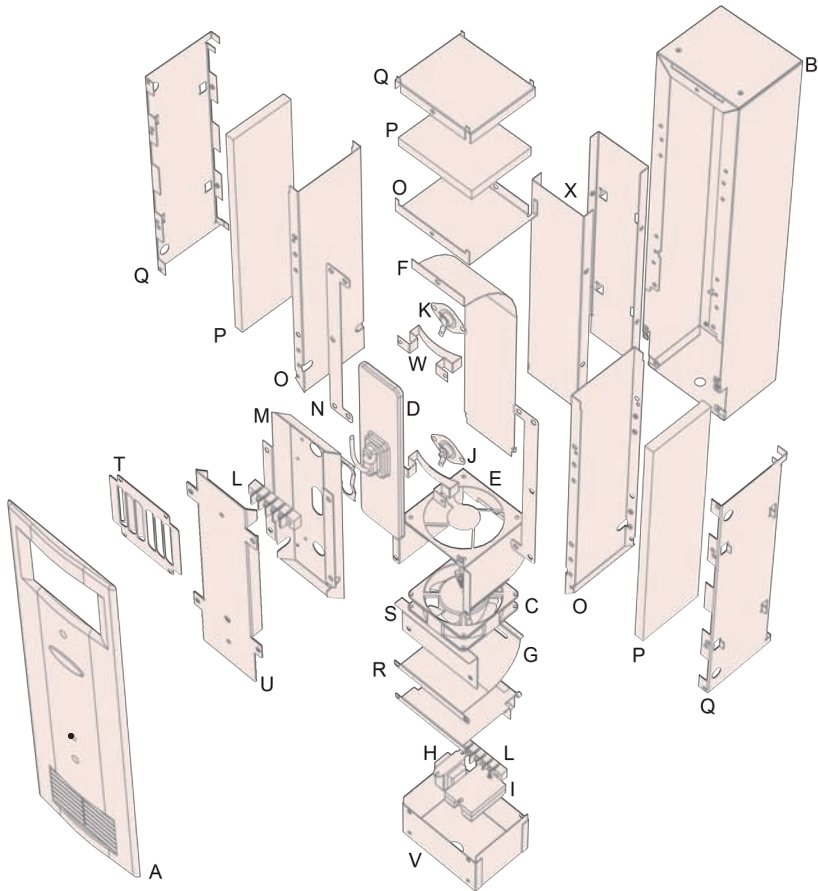

Parts List

A	Front Cover	L	Connection Plate
B	Case	M	IR and Sensor Case Bottom
C	Fan	N	Mounting Bracket
D	Ceramic IR Heating Element	O	Inside Insulator Cover
E	Fan Case	P	Insulator
F	Copper Air Guide	Q	Outside Insulator Cover
G	Bottom Air Guide	R	Electrical Components Divider
H	Fan Transformer	S	Bottom Cover
I	Solid state relay	T	Grill
J	High Heat Sensor	U	IR and Sensor Case Top
K	Fan Sensor	V	Romax Wiring box
		W	IR Retaining clip
		X	Rear baffle assembly

Warranty & Service Information

Five-Year Limited Warranty

BioSmart Technologies, Inc (BT) warrants this product, to the original purchaser or gift recipient, to be free from defects in workmanship and materials under normal use and service, for a period of three years from the date of purchase. BT further warrants the infrared heating elements, to the original purchaser or gift recipient, for a period of two additional years from the date of purchase.

Shipping: BT shall bear the cost of return shipping and repair, or replacement if, during the first 90 days, there is a defect in workmanship or materials. Thereafter, customer shall bear the cost of return shipping and BT shall repair or replace any defective part including all labor for a period of one full year from the date of purchase.

Extended infrared element warranty: For an additional two-year period, BT shall warrant the infrared elements in the heater to be free from defects in workmanship and materials under normal use and service, and shall supply at no cost to the original purchaser replacement elements as required to maintain product in good working order.

Limitations

ALL WARRANTIES IMPLIED BY LAW, INCLUDING THE IMPLIED WARRANTIES OF MERCHANTABILITY AND FITNESS FOR A PARTICULAR PURPOSE, ARE EXPRESSLY LIMITED TO THE DURATION OF THE WARRANTY SET FORTH ABOVE.

Some jurisdictions do not allow limitations on the length of the implied warranty, so the above limitation may not apply to you.

IN NO EVENT SHALL BT BE LIABLE FOR ANY INCIDENTAL OR CONSEQUENTIAL DAMAGES, LOSS OF PROFIT, OR MEDICAL EXPENSES CAUSED BY ANY DEFECT, FAILURE, MISUSE, OR MALFUNCTION OF THE PRODUCT.

Some jurisdictions do not allow the exclusion of limitation of incidental or consequential damages, so the above limitation or exclusion may not apply to you.

Warranty & Service Information *(continued)*

The Company will not be responsible for the damages or losses, direct or indirect, caused by misuse, abuse, accident, negligence, conditions of transportation or storage, or failure to follow instructions. The Company will not be responsible for any statements that are made or published, written or oral, that are inconsistent with this written warranty, or which are misleading or inconsistent with the facts as published in the literature or specifications by the Company.

Warranty Restriction

This warranty is invalid if the factory-applied serial number has been altered or removed from the product.

Warranty Claim Procedure

To obtain warranty service, you must:

1. *Provide proof of purchase* in the form of a Bill of Sale or receipted invoice to show evidence that the unit is within the warranty period or valid serial number to document manufacture date, which ever is the former date will be honored by BioSmart Technologies in lieu of proof of purchase.
2. *Contact the Dealer* you purchased your equipment from for additional instruction.

For more information, or for additional assistance, please call or write:

BioSmart Technologies, Inc.
18324 Cook Road, Suite 6
Yelm, Washington 98597

Customer/Warranty Service: (800) 595-9605



Bio Smart Heaters
Green Technology for a Modern World

North American Distribution and Sales

Bio Smart
Technologies, Inc

18324 Cook Road, Suite 1
Yelm, Washington 98597

Customer/Warranty Service:
(800) 595-9605

Bio Smart™ Infrared Heating Solutions