

Bio Smart Technologies

BioSmart® In-Wall Far Infrared Heaters. *Feel the Difference.*

BIO SMART
Therapeutic Infrared Heat

In-Wall Heater Owner's Manual

*Therapeutic infrared heating systems
for a green, healthy environment*

*with Patented BioSmart®
Air Filtration Technology*



Save these Instructions

Includes:

- Application Guidelines
- User Information & Guidelines
- Operating Instructions
- Warranty & Servicing



BioSmart® BIO-1500FTA
In-Wall Edition Far Infrared Heater

Customer/Warranty Service: 800-595-9605

Table of Contents

| | |
|---|----|
| Congratulations on Your Purchase! | 2 |
| Why Use a BioSmart® Heater | 4 |
| Far Infrared Technology Benefits | 6 |
| Air Filtration Technology Benefits | 7 |
| BioSmart® Heater Features & Functions | 8 |
| Unpacking Your New BioSmart® Heater | 9 |
| Heater Care | 9 |
| USE RESTRICTIONS | 9 |
| How many units do I need? | 10 |
| Installation Instructions | 10 |
| Operation Overview | 11 |
| Operating Instructions at a Glance | 12 |
| Detailed Operating Instructions | 13 |
| Turning Power On | 13 |
| Select your Operating Preference | 13 |
| Setting the Temperature | 13 |
| Switching Between Fahrenheit & Celsius | 13 |
| Setting the Timer | 14 |
| Turning Power Off | 14 |
| Calibrating the Internal Thermometer | 15 |
| Troubleshooting Your BioSmart® Heater | 16 |
| BioSmart® In-Wall Heater Specifications | 17 |
| Diagram of BioSmart® In-Wall Heater | 18 |
| BioSmart® In-Wall Heater Wiring Diagram | 19 |
| Warranty & Service Information | 20 |

Congratulations on Your Purchase!

Congratulations on purchasing your
BioSmart® Therapeutic Ceramic Far Infrared Heater!

One of the best things about using your new BioSmart® Therapeutic Ceramic Far Infrared Heater is the money you will save on gas and electric bills.



Utility field tests show that the BioSmart® Ceramic Far Infrared Heater uses an average of 35% less energy than conventional electric furnace/baseboard systems. And with current fuel prices, the BioSmart® heater will save you even more money than if you were using heating oil or gas heat.

That means drastic reductions in your heating bills -- up to 50%, depending on the type of heating system you have currently installed.

The BioSmart® is a giant of unparalleled efficiency. The far infrared heating technology utilized in the heater warms the objects in the room, as well as the walls and floor. It evenly heats everything in the room, from top to bottom. The heat in the room will never hover uselessly near the ceiling again!

In addition to helping you keep money in your pocket, the BioSmart® goes a step beyond to also enhance your health and the quality of comfort you experience in the heated room. The far infrared Ceramic heating system will not burn, dry out, or pollute the air with impurities. This protects the natural humidity level and produces a soft, ion-balanced heat. Using this soft far infrared heat is a better, more comfortable and more healthy way to heat a room.

There are many therapeutic benefits that can be attributed to far infrared heat. Its use as an integral part of many medical therapies is well documented. Now you can enjoy the benefits of therapeutic far infrared heat with the BioSmart® Ceramic Far Infrared Heater.

Please read the operating instructions carefully for safe and optimum enjoyment of your new BioSmart® Therapeutic Ceramic Far Infrared Heater.

Thank you for your purchase!

*Bio Smart® Infrared Heaters.
Live in Comfort.*

Bio Smart Technologies

Why Use a BioSmart® Heater

BioSmart® heating systems are the ultimate in green technology engineering – easy to install, exceptionally economical and extremely quiet, they produce comfortable, healthy, therapeutic far infrared heat. BioSmart® heaters also purify the air that is processed through them, making them a sanitary source of heat.

Far infrared heat is a highly efficient and therapeutic heat source. By virtue of its shorter wavelength, far infrared is able to penetrate the body and solid objects faster than conventional radiant heat. BioSmart® heating systems use this property of far infrared to evenly and comfortably heat a room. Far infrared heat is the most comfortable source of heat and has been used for years as a therapeutic treatment for cardiovascular and general circulation problems.

Producing far infrared heat requires localized generation of the infrared wave in order to optimize the efficiency and money/energy savings produced when using a far infrared heating source. This design advantage eliminates the need for a ductwork system to distribute the heat through various rooms of a home or office. Eliminating ductwork also eliminates the bacteria, dust, pollen and mold that accumulates in a conventional air conditioning and heating duct system. These pollutants can cause irritation and a potential health problem, especially for those with respiratory sensitivities and allergies, including asthma.

Energy Saving Benefits

It requires less energy to heat the room with far infrared heat than with other conventional heating sources. Additionally, room temperatures of 68 degrees (F) with far infrared heat feel like 72 degrees (F), so you can set the thermostat back 4-5 degrees and experience the same comfort levels utilizing less energy. The temperature on the floor and at the ceiling remains the same without any supplemental fan circulation to keep the temperature balanced throughout the room, even in rooms with high ceilings.

With a BioSmart® heating system you can heat only those spaces which are in use and require the heat. Zoned heating is as much as 50% more economical to use when the entire home or office does not require heat in all areas 100% of the time. The cost savings from this feature alone makes initial installation of the BioSmart® heating system pay for itself in a matter of months. If you really want to save on energy costs, heating with BioSmart® far infrared heat is going to be spectacular.

Quiet Operation

BioSmart® fan systems are virtually silent, distributing heat at over 150 cubic feet per minute per heating unit. They are quieter than forced air systems and do not have the typical cracking and popping sounds heard with baseboard heaters. When rated against other conventional wall heating systems, there is no comparison to the quiet operation of the BioSmart® fan system. BioSmart® fans operate at 18 dB compared to the typical 65 dB for other wall heating systems.

Better Heat Distribution

The nature of the far infrared wave allows the heater to be installed higher on the wall than conventional wall heater systems without compromising the transfer of the heat to the floor. The advantage of the higher installation on the wall guarantees that furniture and other obstructions to the airflow from the heater are eliminated. Child tampering is also eliminated.

Even distribution of the infrared wave is also assured since the air space above the furniture is virtually unrestricted. When conventional heat sources are vented through the ceiling to save on construction costs, the heat remains on the ceiling and must be pushed down with ceiling fans. This is not required with infrared heat.

Accurate Temperature

BioSmart® heating systems utilize state of the art electronics and internal electronic thermostats for pin-point, one-degree accuracy. That means more accurate control of comfort level settings and a warm, comfortable environment for you and your family.

Cost-Effective

Components in the BioSmart® heating system are designed to last 10 times longer than other wall heaters. BioSmart® warranty coverage and service procedures are simple to follow and they can be serviced in ten minutes or less should repair be required. The cost to purchase and install a BioSmart® infrared heating system for your entire home is usually much cheaper than the cost of installing a central forced air heating system.

Flexible Size & Wattage Applications

BioSmart® In-Wall heaters have two settings: 1500 watts for conventional room heating and 750 watts for smaller rooms, bathrooms, hallways, and closets.

Patented Proprietary Technology

BioSmart® heaters contain a proprietary, high-efficiency far infrared heat exchanger which produces more far infrared heat per kilowatt than conventional ceramic, quartz, or carbon plates. Patent pending coverage of more than 30 distinct features in the BioSmart® heater are what makes the BioSmart® technology a truly unique energy efficient heat source for your home or office.

Quality Assurance

BioSmart® heating systems come with C-TUV-US certifications representing equivalent approvals both in UL and CSA classifications. BioSmart® heaters are manufactured in Taiwan and China through AcePower Electronics, which includes a consortium of engineers, vendors and manufacturers. AcePower Electronics is also a certified ISO 9000 manufacturer and the exclusive manufacturer for BioSmart Technologies heaters and air purifiers.

WARNING

ANY REQUIRED SERVICE SHOULD ONLY BE PERFORMED
BY AN AUTHORIZED SERVICE REPRESENTATIVE



CAUTION: RISK OF ELECTRICAL SHOCK
DO NOT OPEN
NO USER-SERVICEABLE PARTS INSIDE



USE RESTRICTIONS

READ ALL INSTRUCTIONS BEFORE USING THE HEATER

- DO NOT alter the heater's design, or you will void the warranty.
- DO NOT block the front of the heater.
- DO NOT place anything directly in front of the heater.
- DO NOT cover the unit as this may block airflow and cause the heater to malfunction.
- DO NOT insert or allow foreign objects to enter any ventilation or exhaust opening as this may cause an electric shock or damage the heater.
- Heater has hot parts inside. DO NOT use it in areas where gasoline, paint, or flammable liquids are used or stored.
- Do not block air intakes or exhaust in any manner.
- Use this heater only as described in this manual. Any other use not recommended by the manufacturer may cause fire, electrical shock, or injury to persons.

SAVE THESE INSTRUCTIONS

Unpacking Your New BioSmart® Heater

1. INSPECT the package for any obvious damage.
2. UNPACK the heater: cut open taped box edges, fold back box flaps. Gently turn entire box upside down; lift box from protective packaging.
3. REMOVE the protective packaging materials from the inside of the heater's heat exchanger, making sure that all combustible materials have been removed from around the black ceramic heating elements.
4. INSPECT the unit to make sure that there are no cracks in the black ceramic heating elements.
5. PROCEED with the "Installation Instructions" on page 10.

Heater Care

General Maintenance and Care

Routinely inspect the air registers on the unit to make sure that no dust has accumulated. Vacuum as you would any conventional air duct.

It is suggested that an annual dusting of the ceramic plates be performed in order to eliminate any residual accumulation of dust during the summer months. In order to accomplish this, the front plastic panel must be removed by removing the four screws and lifting up to release the panel from the top clip.

Far Infrared Technology Benefits

BioSmart Far Infrared vs Standard Coil-Type Radiant Heater

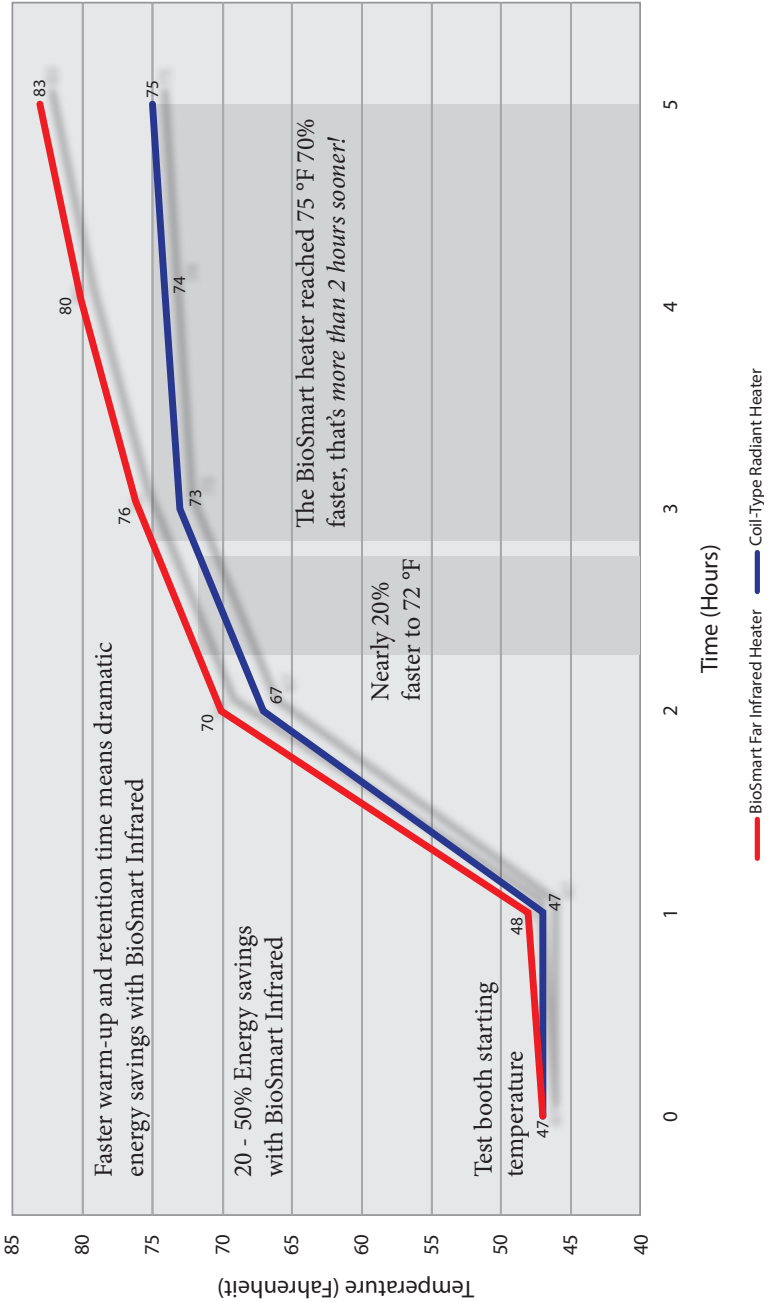

BioSmart® Air Filtration Technology Benefits

3-Stage Air Purification

The BIO-1500FTA infrared heater includes BioSmart's patented state of the art air purification technology. This advanced technology has been available in BioSmart's line of portable infrared heaters for the past 4 years. Now it is also available in the BioSmart On-Wall and In-Wall heating systems.

The BioSmart air purification module consists of a UV emitter, a TiO₂ membrane, and a negative ion generator for conditioning the air. It can run year around with or without the heater.

Features of the UV / TiO₂ Air Filtration System

- The UV / TiO₂ technology does not rely on filters to remove and destroy harmful substances in the air.
- This type of purification technology converts harmful particulates (virus' and bacteria) and toxic gases (VOC's) into safer compounds such as carbon dioxide and water.
- UV / TiO₂ technology has the ability to eliminate particles as small as 0.001 microns, including angstrom size VOC's that can absorb into your lungs and cause damage (HEPA filters are only able to filter out particles as small as 0.3 microns).
- The UV / TiO₂ units in the BioSmart heating systems produce no ozone. These units have been found to be much safer than ozone and ionization, and the technology works wonderfully well for those with asthma, allergies, and multiple chemical sensitivities.

**BioSmart Patented Air Filtration
Technology is number one world wide in
filtration efficiency**

BioSmart® Heater Features & Functions

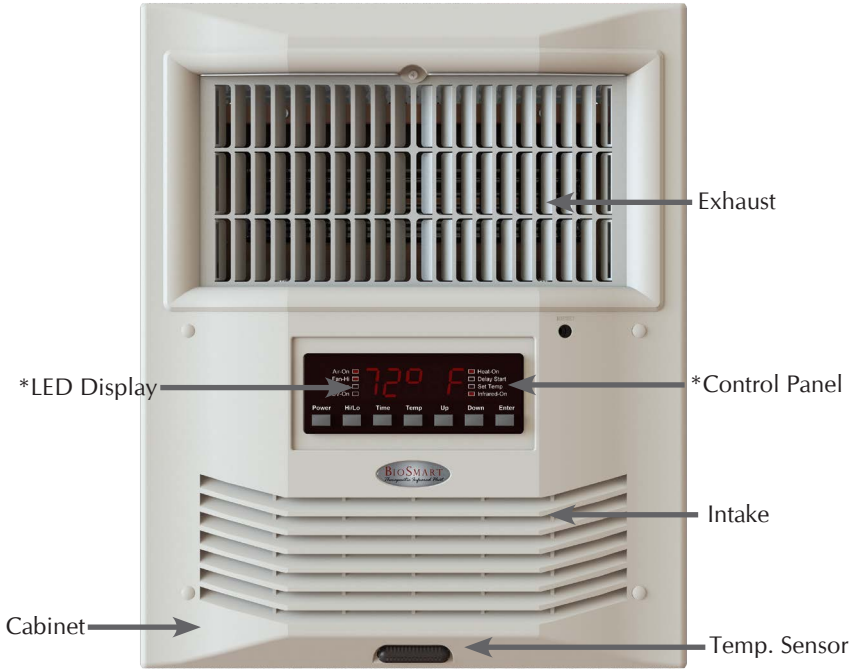

*Control Panel & LED Display

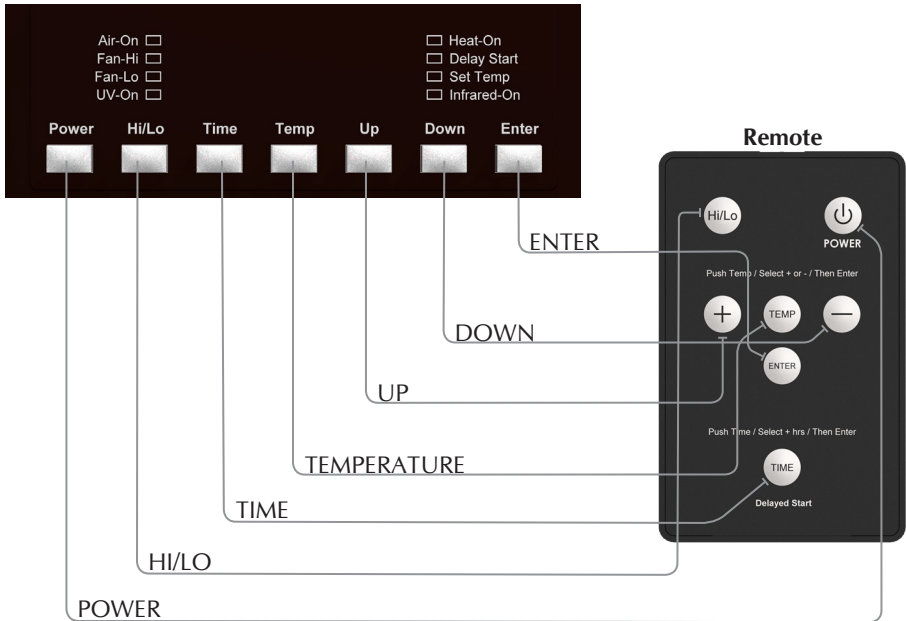

How many units do I need?

When determining the number of units you will need, take into consideration:

- The insulation factor, and window size & placement
- The mean outside temperature during the coldest days of the year
- The size of each room
- The overall size of the home
- The number of floors involved
- The entrance and egress points

In lieu of overall engineering calculations and thermal loss calculations, a general rule of thumb can be applied to determine the number of units you will need if using the in-wall unit as a primary heating source:

New construction (coldest day above 5 degrees), standard insulation, one window per room:

Room size up to 500 sq. feet: 1 unit

Room size above 500 to 1000 sq. feet: 2 units

New construction (coldest day below 5 degrees) & all remodels, standard insulation:

Room size up to 350 sq. feet: 1 unit

Room size above 350 to 700 sq. feet: 2 units

Hallways and Nooks: 1 unit per 400 sq. feet

Closets and Bathrooms: 1 unit per 400 sq. feet

Installation Instructions

Easy Installation

The BIO-1500FTA was designed for installation in a standard 2"x4" wall with either 1/2" or 5/8" sheetrock. The unit comes with brackets for both new installations and retrofits.

The BIO-1500FTA can be mounted from 12" above the floor up to 12" down from the ceiling.

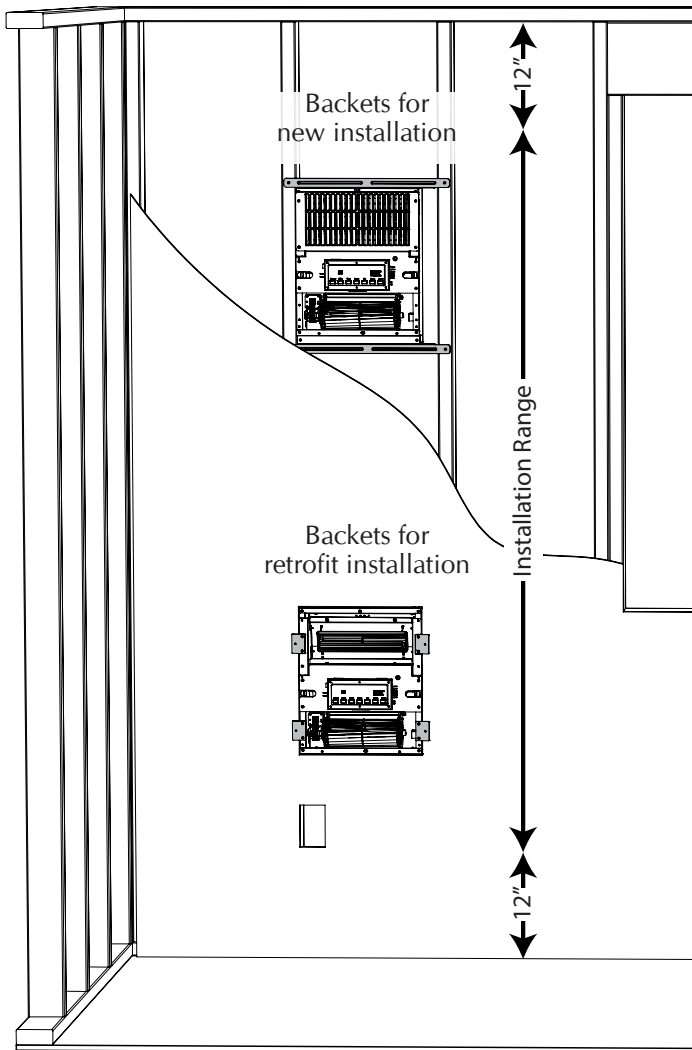

Operation Overview

The units are self-regulating. When the heater is turned on and the heating elements have come up to full temperature, the heater fan will turn on to increase the airflow into the room. The fan will remain running even after the heating elements have been shut down by the thermostat, in order to distribute the remaining heat in the heating elements into the room and to prevent overheating of the heating elements. Once the heating elements have cooled sufficiently, the fan will turn off.

Operating Instructions at a Glance

Turning Power On

Press the POWER button on the left side of the Control Panel. The heater's ceramic heating elements will light up inside the heater. After a few minutes, once the air within the heater is warm, the heater fan will begin to operate.

Select your Operating Preference

The air purification can be set to run independently of the heating. Use the Enter key to cycle between:

Heating only -> Heat plus air purification -> Air purification only

Pressing Enter again resets the cycle.

Setting the Temperature

This feature allows you to set the temperature that your heater will maintain.

Press the temperature (TEMP) button on the Control Panel; the SET TEMP indicator will illuminate and the temperature display will flash. Use the UP and DOWN buttons to select the temperature and press the ENTER button. The SET TEMP light will turn off, and the temperature is now set.

Setting the Timer

This feature allows you to set a future time for the heater to turn itself on. For example, if you set the time for 1 hour, the heater will turn on in 1 hour.

1. Turn the power off (heater must be powered off to use the timer feature).
2. Press the TIME button on the Control Panel—the two zeros to the right will flash (:00), and the DELAY START indicator will illuminate.
3. Press the UP or DOWN button to select desired number of minutes (up to 59 minutes) that you would like the heater to wait to turn itself on.
4. Press the ENTER button—the two zero buttons to the left will flash (00:), indicating 0 hours have been set.
5. Press the UP or DOWN button to the desired number of hours (up to 24 hours), and then press the ENTER button.
6. DELAY START indicator will flash until the unit comes on after waiting the period of time you have set.
7. To cancel the timer, press the POWER button and the timer will stop.

Switching Between Fahrenheit & Celsius

Press the DOWN & ENTER buttons simultaneously and hold for about 3 seconds. The display will update automatically.

Turning Power Off

Press the POWER button located on the left side of the Control Panel. The sound of the heater fan will continue until the heat has been completely vented, thus protecting the unit and preventing waste by cycling the remaining heat into the room. (NOTE: DO NOT unplug the heater until the sound of the fan has stopped. Doing so may cause damage to the unit.)

Detailed Operating Instructions

Turning Power On

1. Press the POWER button on the left side of the Control Panel. The heater's ceramic heating elements will turn on inside the heater.
2. After a few minutes, once the air within the heater is warm, the heater fan will begin to operate.

Select your Operating Preference

The air purification can be set to run independently of the heating.

1. Press Enter once to select heating only.
2. Press Enter again for heat plus air purification.
3. Press Enter again for air purification only (can be used year around).

Pressing Enter again resets the cycle to heating only.

Setting the Temperature

This feature allows you to set the temperature that your heater will maintain.

1. Press the temperature (TEMP) button on the Control Panel; the SET TEMP indicator will illuminate and the temperature display will flash.
2. Use the UP and DOWN buttons to select the temperature, press ENTER.
3. The SET TEMP light will turn off, and the temperature is now set.

Switching Between Fahrenheit & Celsius

Press the DOWN & ENTER buttons simultaneously and hold for about 3 seconds. The display will update automatically.



Detailed Operating Instructions - Continued

Setting the Timer

This feature allows you to set a future time for the heater to turn itself on. For example, if you set the time for 1 hour, the heater will turn on in 1 hour.

1. Turn the power off (heater must be powered off to use the timer feature).
2. Press the TIME button on the Control Panel—the two zeros to the right will flash (:00), indicating 0 minutes have been set, and the DELAY START indicator will illuminate.
3. Press the UP or DOWN button to select desired number of minutes (up to 59 minutes) that you would like the heater to wait to turn itself on.
4. Press the ENTER button—the two zero buttons to the left will flash (00:), indicating 0 hours have been set.
5. Press the UP or DOWN button to the desired number of hours (up to 24 hours), and then press the ENTER button.
6. DELAY START indicator will flash until the unit comes on after waiting the period of time you have set.
7. To cancel the timer, press the POWER button and the timer will stop.

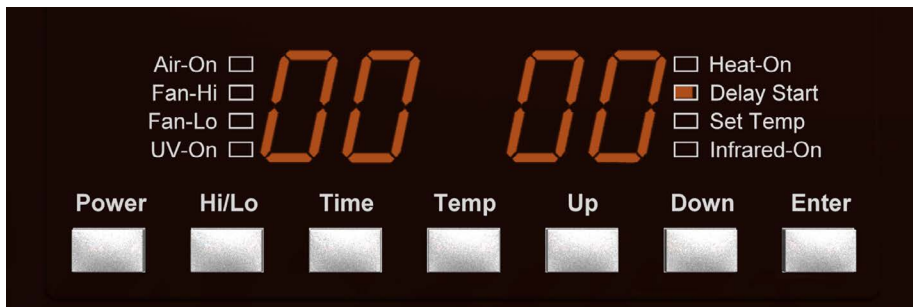

Turning Power Off

1. Press the POWER button located on the left side of the Control Panel. DO NOT UNPLUG, read further:
2. The sound of the heater fan will continue until the heat has been completely vented, thus protecting the unit and preventing waste by cycling the remaining heat into the room. (DO NOT unplug the heater until the sound of the fan has stopped. Doing so may cause damage to the unit.)

Calibrating the Internal Thermometer

The internal thermometer in the heater can be re-calibrated to match the room thermometer if it is not sufficiently accurate the way the heater arrived from the factory. This procedure can be completed directly with the PCB controls on the front panel:

1. Turn the heater on.
2. Determine base-line room temperature in the heater by pressing “up” and “down” at the same time. The room temperature detected by the heater thermostat will be displayed on the screen for 15 seconds. This may or may not correspond with the wall thermostat setting. This is what you are about to change.
3. Release the buttons and wait for 15 seconds for the unit to return to its regular functions.
4. To continue with the recalibration, press “up” and “enter” at the same time and hold until the following appears in the window: “8.8.8.8.8”
5. Press “enter” again. Ignore the existing number which is -9 to +9. This number is the arbitrary adjustment between the thermostat sensor and the temperature that was displayed on the screen when you pushed the “up and “down” buttons at the same time in Step 1.
6. To adjust the temperature that was displayed on the screen in Step 1, press the “up” or “down” buttons to obtain a higher or lower base-line temperature for the internal thermostat on the heater.
7. Once the desired temperature is displayed on the screen, press the “enter” button again to exit the programming mode. The temperature setting displayed on the heater screen will now be measured against the new thermostat setting you have programmed into the heater.

This entire procedure can be followed skipping step 1 and using the temperature setting on any wall thermostat instead of the temperature setting on the internal thermometer in the heater. Remember, the internal temperature measurement on the thermostat is only your starting reference point and it is strictly arbitrary. It is set at the factory and is usually within 2 degrees of reality.

By following this procedure, you are setting the unit to precisely match the wall thermostat rather than the factory installed thermostat setting. Either set-point is fine depending upon the customer’s preference.

Troubleshooting Your BioSmart® Heater

| Problem | Solution |
|---|--|
| Heater's airflow is reduced. | Check for any objects that could obstruct airflow. If the heater's airflow is still diminished or has stopped, please call Customer Service. |
| Heater stays on after POWER is pushed. | The heater is cooling down, this is a normal function. DO NOT unplug the heater until you no longer hear the fan. |
| Heater fan still on 20 minutes after shut-down. | This is most likely a defective fan relay. Please call Customer Service. |
| Heater display shows a line of dots. | After a period of inactivity, the heater will enter into a "screen saver" mode to conserve power. When any function key is pressed, the display will reappear. |
| Heater temperature does not match central thermostat temperature. | Refer to the Calibrating the Internal Thermometer instructions in this manual for programming instructions to match heater thermostat settings with your existing wall thermostat. |
| Heater will not turn on. | Test the outlet to make sure there is power available and then check the heater display for the flashing TIME DELAY light. Press the POWER button to turn off the timer and resume normal operation of the heater. |
| Heater doesn't seem to be getting hot enough. | Most likely, one of the ceramic elements is burnt out or the connection to the element is bad. Call Customer Service for help, the defective ceramic plate may need replacing. |
| The heater is noisy. | Check for obstructions to the fan blades. If there are none, you have a defective fan. Please call Customer Service. |

BioSmart® In-Wall Heater Specifications

Model BIO-1500FTA

- **Cabinet:** All metal - 22 & 24 gauge with synthetic, paintable shell
- **Weight:** 19 lbs
- **Dimensions:** 18" x 14.5" x 5" (HxWxD)
- **Power Requirements:** 120 or 220 volt AC
- **Power Consumption:** 12.5A @ 120 volt, 6.75A @ 220 volt, 1500 watt
- **Chassis Safety Insulation:** Exceeds all government and independent laboratory standards for safety in an installed heating appliance (a safety standard that exceeds other manufacturer's specifications).
- **Internal Ceramic Blanket:** Provides R45 insulation between the wall and the heater. The heater cabinet remains cool to the touch while delivering warm (105° C) far infrared heat into the room.
- **Control Panel:** Digital – large numbers
- **Thermostat:** 3 probe – Electronic Digital; Range 37 - 86 °F
- **Thermostat Accuracy:** ±1° (1 degree up and 1 degree down)
- **Delayed Start Function • Automatic Restart • Safety Cut-Off**
- **Life Expectancy:** 25+ Years
- **Remote Control**
- **Zoned Heat Capability**
- **Heat Type:** therapeutic far infrared heat
- **Heat Chamber:** Copper-lined for maximum ion transfer
- **Heating Elements:** 2 -750 watt ceramic far infrared emitters
- **Infrared Emitter Life Expectancy:** 40,000 hours
- **Heat Output:** 6,800 BTU infrared heat
- **Fan System:** Dual Speed, high-output, ball bearing laminar-flow
- **Fan Noise Level:** 18 dB - practically silent
- **Listed Approvals:** C-TUV-US (International UL Equivalent)
- **Warranty:** 5-Year limited



BIO-1500FTA

Diagram of BioSmart® In-Wall Heater

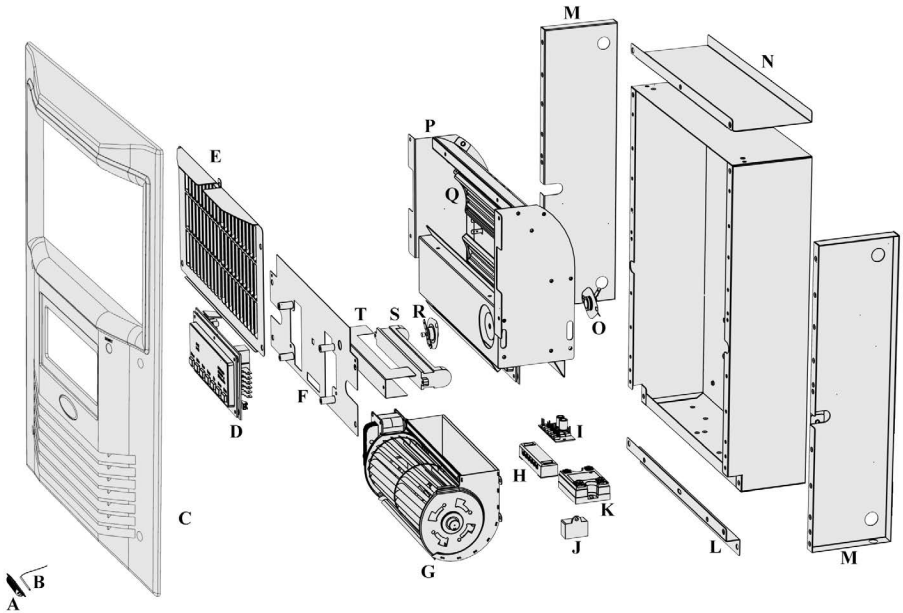

- A. Sensor Cover
- B. Temperature Sensor
- C. Cover
- D. Control Panel
- E. Exhaust Grill
- F. CP Mounting Plate
- G. Scroll Fan
- H. Connection Plate
- I. PC Board
- J. Ionizer
- K. Solid state relay
- L. Bottom Case Cover
- M. Insulator Covers
- N. Top Insulator Cover
- O. Fan Sensor
- P. Heater Core
- Q. Ceramic Heating Elements
- R. High Limit Reset
- S. UV Light
- T. UV Light Shield

Warranty & Service Information

Five-Year Limited Warranty

BIOSMART TECHNOLOGIES (BT) warrants this product, to the original purchaser or gift recipient, to be free from defects in workmanship and materials under normal use and service, for a period of one year from the date of purchase. BT further warrants the infrared heating elements and fan motors, to the original purchaser or gift recipient, for a period of four additional years from the date of purchase.

Extended Warranty Details: For an additional four-year period, BT shall warrant the infrared elements and fan motors in the heater to be free from defects in workmanship and materials under normal use and service, and shall supply at no cost, excluding shipping, to the original purchaser replacement elements or fans as required to maintain product in good working order. Limitations on labor: During the first year of the warranty, BT will reimburse the customer \$30 for in home contractor service or 100% of labor cost provided that the defective unit is shipped back to BT for service.

Shipping: BT or its Dealer shall bear the cost of return shipping and repair, or replacement if, during the first 90 days, there is a defect in workmanship or materials. Thereafter customer shall bear the cost of return shipping to BT or repair the unit in home per the above terms for labor reimbursement. If BT receives the unit for repair, defective parts, including all labor, will be provided by BT for a period of 1 full year from the date of purchase.

Limitations

ALL WARRANTIES IMPLIED BY LAW, INCLUDING THE IMPLIED WARRANTIES OF MERCHANTABILITY AND FITNESS FOR A PARTICULAR PURPOSE, ARE EXPRESSLY LIMITED TO THE DURATION OF THE WARRANTY SET FORTH ABOVE.

Some jurisdictions do not allow limitations on the length of the implied warranty, so the above limitation may not apply to you.

Warranty & Service Information (continued)

IN NO EVENT SHALL BT BE LIABLE FOR ANY INCIDENTAL OR CONSEQUENTIAL DAMAGES, LOSS OF PROFIT, OR MEDICAL EXPENSES CAUSED BY ANY DEFECT, FAILURE, MISUSE, OR MALFUNCTION OF THE PRODUCT.

Note: Some jurisdictions do not allow the exclusion of limitation of incidental or consequential damages, so the above limitation or exclusion may not apply to you. The Company will not be responsible for the damages or losses, direct or indirect, caused by misuse, abuse, accident, negligence, conditions of transportation or storage, or failure to follow instructions.

The Company will not be responsible for any statements that are made or published, written or oral, that are inconsistent with this written warranty, or which are misleading or inconsistent with the facts as published in the literature or specifications by the Company.

Warranty Restriction

This warranty is invalid if the factory-applied serial number has been altered or removed from the product.

Warranty Claim Procedure

To obtain warranty service, you must:

1. Contact the Dealer you purchased your equipment from for additional instruction.
2. Provide proof of purchase, if requested, in the form of a Bill of Sale or receipted invoice to show evidence that the unit is within the warranty period.

*Bio Smart® Far Infrared Heaters
Green Technology for a Modern World*

North American Distribution and Sales

Bio Smart Technologies

18324 Cook Road, Suite 1
Yelm, Washington 98597

Customer/Warranty Service:
800-595-9605

Bio Smart® Far Infrared Heaters