

Bio Smart Technologies

BioSmart® In-Wall Far Infrared Heaters. *Feel the Difference.*



In-Wall Heater Owner's Manual

*Therapeutic infrared heating systems
for a green, healthy environment*

*with Patented BioSmart®
Air Filtration Technology*



Save these Instructions

Includes:
Application Guidelines
User Information & Guidelines
Operating Instructions
Warranty & Servicing



BioSmart® BIO-1000F
In-Wall Edition Far Infrared Heater

Customer/Warranty Service: 800-595-9605

Table of Contents

Congratulations on Your Purchase!.....	2
Why Use a BioSmart® Heater.....	4
Far Infrared Technology Benefits.....	6
Unpacking Your New BioSmart® Heater.....	7
Heater Care.....	7
USE RESTRICTIONS	7
BioSmart® 500F Features & Functions.....	8
BioSmart® 1000F Features & Functions.....	9
How many units do I need?.....	10
Installation Instructions.....	10
Wiring Diagrams.....	13
BIO-1000F/120v Wiring Schematic.....	13
BIO-500F/120v Wiring Schematic.....	13
For Your Safety/Warning.....	14
For Best Performance.....	14
Operating Instructions.....	14
Maintenance.....	14
Troubleshooting Your BioSmart® Heater.....	15
BioSmart® 1000F In-Wall Heater Specifications	16
BioSmart® 500F In-Wall Heater Specifications	17
Diagram of BioSmart® 1000F In-Wall Heater.....	18
Diagram of BioSmart® 500F In-Wall Heater.....	19
Warranty & Service Information.....	20

Congratulations on Your Purchase!

Congratulations on purchasing your
BioSmart® Therapeutic Ceramic Far Infrared
Heater!

One of the best things about using your new BioSmart® Therapeutic Ceramic Far Infrared Heater is the money you will save on gas and electric bills.



Utility field tests show that the BioSmart® Ceramic Far Infrared Heater uses an average of 35% less energy than conventional electric furnace/baseboard systems. And with current fuel prices, the BioSmart® heater will save you even more money than if you were using heating oil or gas heat.

That means drastic reductions in your heating bills -- up to 50%, depending on the type of heating system you have currently installed.

The BioSmart® is a giant of unparalleled efficiency. The far infrared heating technology utilized in the heater warms the objects in the room, as well as the walls and floor. It evenly heats everything in the room, from top to bottom. The heat in the room will never hover uselessly near the ceiling again!

In addition to helping you keep money in your pocket, the BioSmart® goes a step beyond to also enhance your health and the quality of comfort you experience in the heated room. The far infrared Ceramic heating system will not burn, dry out, or pollute the air with impurities. This protects the natural humidity level and produces a soft, ion-balanced heat. Using this

soft far infrared heat is a better, more comfortable and more healthy way to heat a room.

There are many therapeutic benefits that can be attributed to far infrared heat. Its use as an integral part of many medical therapies is well documented. Now you can enjoy the benefits of therapeutic far infrared heat with the BioSmart® Ceramic Far Infrared Heater.

Please read the operating instructions carefully for safe and optimum enjoyment of your new BioSmart® Therapeutic Ceramic Far Infrared Heater.

Thank you for your purchase!

*Bio Smart® Infrared Heaters.
Live in Comfort.*

Bio Smart Technologies

Why Use a BioSmart® Heater

BioSmart® heating systems are the ultimate in green technology engineering – easy to install, exceptionally economical and extremely quiet, they produce comfortable, healthy, therapeutic far infrared heat. BioSmart® heaters also purify the air that is processed through them, making them a sanitary source of heat.

Far infrared heat is a highly efficient and therapeutic heat source. By virtue of its shorter wavelength, far infrared is able to penetrate the body and solid objects faster than conventional radiant heat. BioSmart® heating systems use this property of far infrared to evenly and comfortably heat a room. Far infrared heat is the most comfortable source of heat and has been used for years as a therapeutic treatment for various conditions including muscle and joint pain, stiffness, and cardiovascular and general circulation problems.

Producing far infrared heat requires localized generation of infrared wave in order to optimize the efficiency and money/energy savings produced when using a far infrared heating source. This design advantage eliminates the need for a ductwork system to distribute the heat through various rooms of a home or office. Eliminating ductwork also eliminates the bacteria, dust, pollen and mold that accumulates in a conventional air conditioning and heating duct system. These pollutants can cause irritation and a potential health problem, especially for those with respiratory sensitivities and allergies, including asthma.

Energy Saving Benefits

It requires less energy to heat the room with far infrared heat than with other conventional heating sources. Additionally, room temperatures of 68 degrees (F) with far infrared heat feel like 72 degrees (F), so you can set the thermostat back 4-5 degrees and experience the same comfort levels utilizing less energy. The temperature on the floor and at the ceiling remains the same without any supplemental fan circulation to keep the temperature balanced throughout the room, even in rooms with high ceilings.

With a BioSmart® heating system you can heat only those spaces which are in use and require the heat. Zoned heating is as much as 50% more economical to use when the entire home or office does not require heat in all areas 100% of the time. The cost savings from this feature alone makes initial installation of the BioSmart® heating system pay for itself in a matter of months. If you really want to save on energy costs, heating with BioSmart® far infrared heat is going to be spectacular.

Quiet Operation

BioSmart® fan systems are virtually silent, distributing heat at over 150 cubic feet per minute per heating unit. They are quieter than forced air systems and do not have the typical cracking and popping sounds heard with baseboard heaters. When rated against other conventional wall heating systems, there is no comparison to the quiet operation of the BioSmart® fan system. BioSmart® fans operate at 18 dB compared to the typical 65 dB for other wall heating systems.

Better Heat Distribution

The nature of far infrared waves allows the heater to be installed higher on the wall than conventional wall heater systems without compromising the transfer of the heat to the floor. The advantage of the higher installation on the wall guarantees that furniture and other obstructions to the airflow from the heater are eliminated. Child tampering is also eliminated.

Even distribution of infrared wave is also assured since the air space above the furniture is virtually unrestricted. When conventional heat sources are vented through the ceiling to save on construction costs, the heat remains near the ceiling and must be pushed down with ceiling fans. This is not required with infrared heat.

Accurate Temperature

BioSmart® heating systems utilize state of the art electronics and internal electronic thermostats for pin-point, one-degree accuracy. That means more accurate control of comfort level settings and a warm, comfortable environment for you and your family.

Cost-Effective

Components in the BioSmart® heating system are designed to last longer than other wall heaters. BioSmart® warranty coverage and service procedures are simple to follow and the heaters can be serviced in ten minutes or less should repair be required. The cost to purchase and install a BioSmart® infrared heating system for your entire home is usually much cheaper than the cost of installing a central forced air heating system.

Patented Proprietary Technology

BioSmart® heaters contain a proprietary, high-efficiency far infrared heat exchanger which produces more far infrared heat per kilowatt than conventional ceramic, quartz, or carbon plates. Patent pending coverage of more than 30 distinct features in the BioSmart® heater are what makes the BioSmart® technology a truly unique energy efficient heat source for your home or office.

Quality Assurance

BioSmart® heating systems come with C-TUV-US certifications representing equivalent approvals both in UL and CSA classifications. BioSmart® heaters are manufactured in Taiwan and China through AcePower Electronics, which includes a consortium of engineers, vendors and manufacturers. AcePower Electronics is also a certified ISO 9000 manufacturer and the exclusive manufacturer for BioSmart Technologies heaters and air purifiers.

Far Infrared Technology Benefits

BioSmart Far Infrared vs Standard Coil-Type Radiant Heater

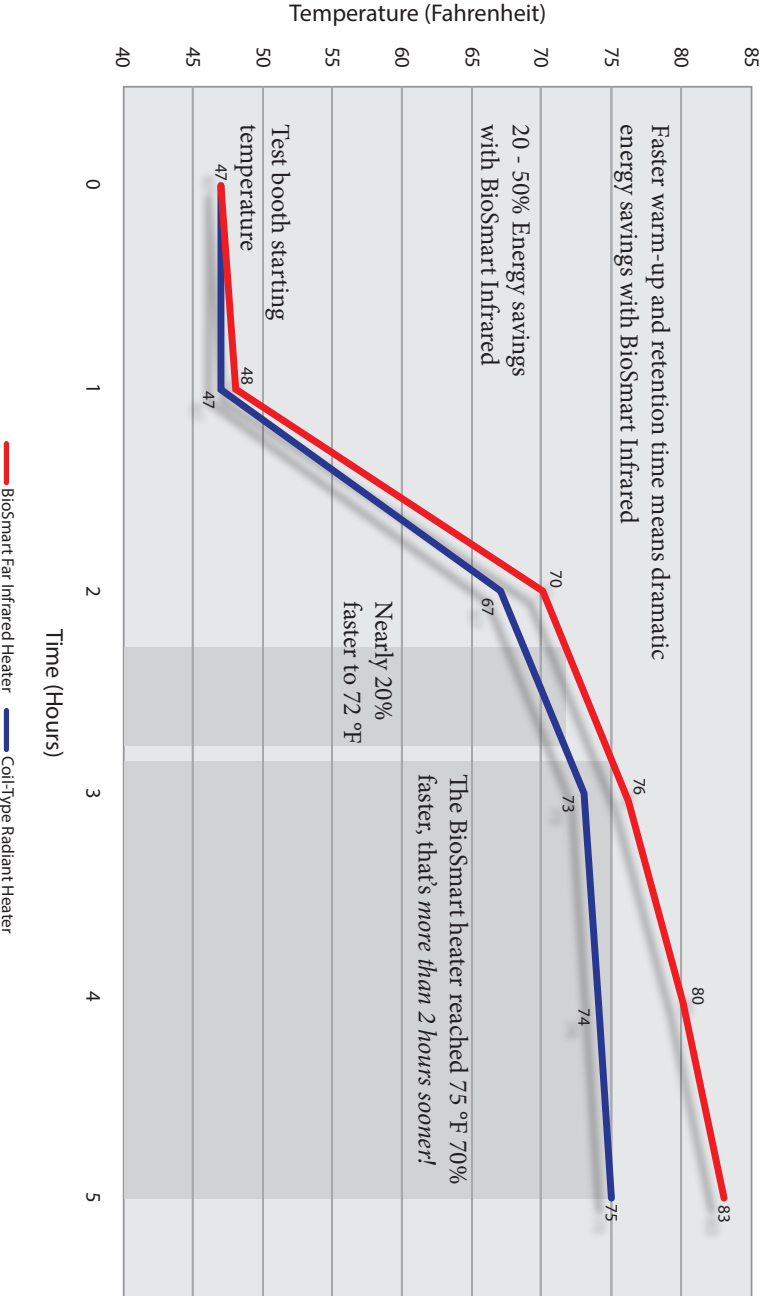

WARNING

ANY REQUIRED SERVICE SHOULD ONLY BE PERFORMED BY
AN AUTHORIZED SERVICE REPRESENTATIVE



CAUTION: RISK OF ELECTRICAL SHOCK
DISCONNECT POWER BEFORE SERVICING



USE RESTRICTIONS

READ ALL INSTRUCTIONS BEFORE USING THE HEATER

- DO NOT alter the heater's design, or you will void the warranty.
- DO NOT block the front of the heater.
- DO NOT place anything directly in front of the heater.
- DO NOT cover the unit as this may block airflow and cause the heater to malfunction.
- DO NOT insert or allow foreign objects to enter any ventilation or exhaust opening as this may cause an electric shock or damage the heater.
- Heater has hot parts inside. DO NOT use it in areas where gasoline, paint, or flammable liquids are used or stored.
- Do not block air intakes or exhaust in any manner.
- Use this heater only as described in this manual. Any other use not recommended by the manufacturer may cause fire, electrical shock, or injury to persons.

SAVE THESE INSTRUCTIONS

Unpacking Your New BioSmart® Heater

1. INSPECT the package for any obvious damage.
2. UNPACK the heater: cut open taped box edges, fold back box flaps. Gently turn entire box upside down; lift box from protective packaging.
3. REMOVE the protective packaging materials from the inside of the heater's heat exchanger, making sure that all combustible materials have been removed from around the black ceramic heating elements.
4. INSPECT the unit to make sure that there are no cracks in the black ceramic heating elements.
5. PROCEED with the "Installation Instructions" on page 10.

Heater Care

General Maintenance and Care

Routinely inspect the air registers on the unit to make sure that no dust has accumulated. Vacuum as you would any conventional air duct.

It is suggested that an annual dusting of the ceramic plates be performed in order to eliminate any residual accumulation of dust during the summer months. In order to accomplish this, the front plastic panel must be removed by removing the four screws and lifting up to release the panel from the top clip.

BioSmart® 500F Features & Functions



BioSmart® 1000F Features & Functions

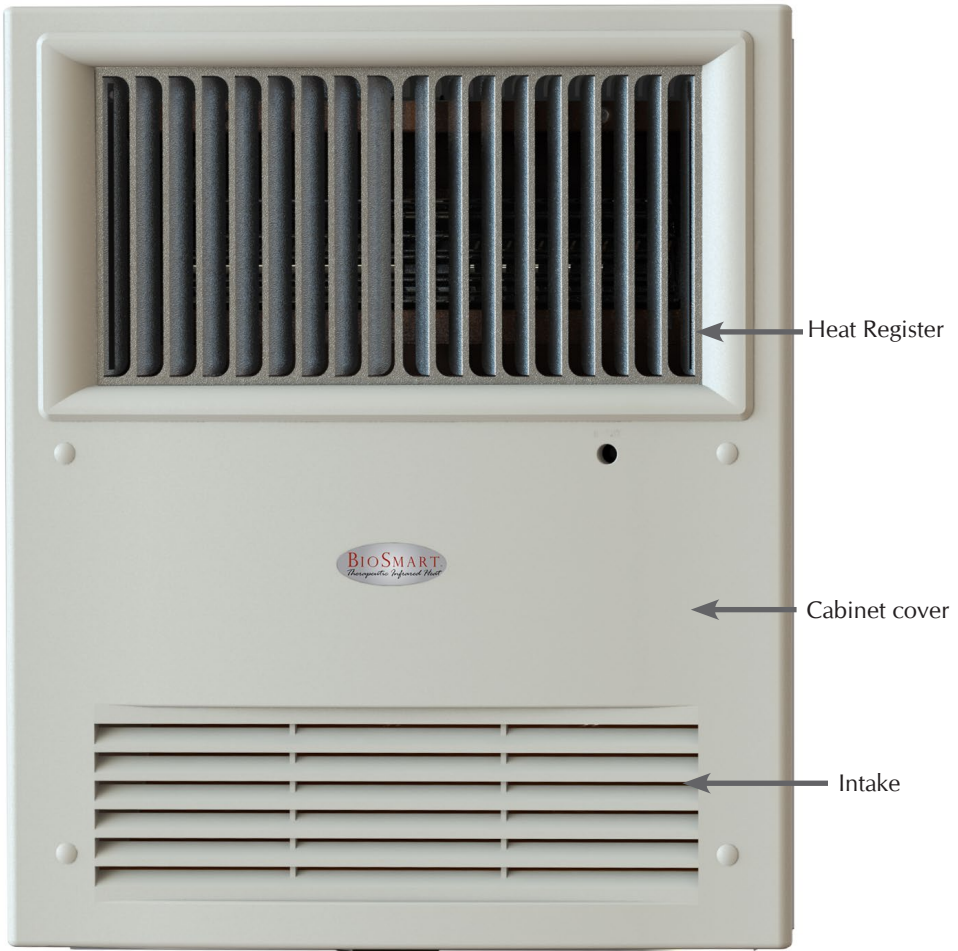

How many units do I need?

When determining the number of units you will need, take into consideration:

- The insulation factor, and window size & placement
- The mean outside temperature during the coldest days of the year
- The size of each room
- The overall size of the home
- The number of floors involved
- The entrance and egress points

In lieu of overall engineering calculations and thermal loss calculations, a general rule of thumb can be applied to determine the number of units you will need if using the in-wall unit as a primary heating source:

New construction (coldest day above 5 degrees), standard insulation, one window per room:

Room size up to 500 sq. feet: 1 unit

Room size above 500 to 1000 sq. feet: 2 units

New construction (coldest day below 5 degrees) & all remodels, standard insulation:

Room size up to 350 sq. feet: 1 unit

Room size above 350 to 700 sq. feet: 2 units

Hallways and Nooks: 1 unit per 400 sq. feet

Closets and Bathrooms: 1 unit per 400 sq. feet

Installation Instructions

Easy Installation

The BIO-500F/1000F were designed for installation in a standard 2"x4" wall with either 1/2" or 5/8" sheetrock. The units comes with brackets for both new installations and retrofits.

The heaters can be mounted from 12" above the floor up to 12" down from the ceiling.

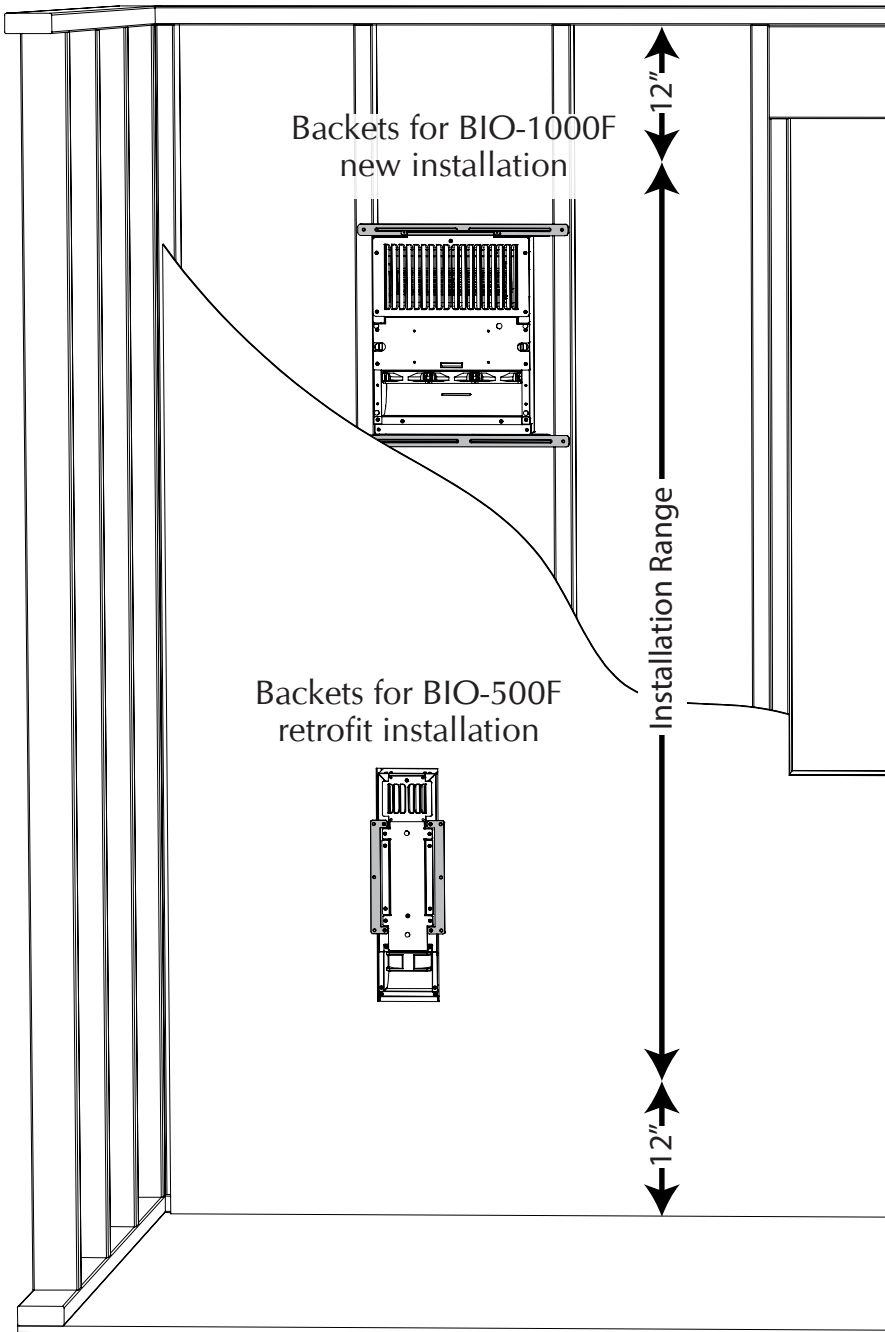

Heater Wiring

Regardless of the model chosen, there are 5 wires inside the base of the heater which must be wired correctly. Three wire contacts are required to obtain the power source. The wiring code is the same for 120 volt units.

The heater must be provided with a disconnect device (switch/breaker) from the supply mains having a contact separation in all poles that provide full disconnection with a contact separation of at least 3 mm.

On the large in-wall unit the black is hot, the red is neutral, and the green is ground. On the small in-wall unit the black is hot, the blue is neutral and the green is ground. On both units the yellow and white wires go directly to the thermostat.

No external power supply is needed. Any attempt to attach an external power supply will cause damage to the internal components and will result in product failure.

When connecting multiple units to a single thermostat, the units must be connected in parallel with all yellow and all white wire leads connected to their same respective terminals on the thermostat.

Failure to follow these guidelines will result in internal transformer failure and product failure.

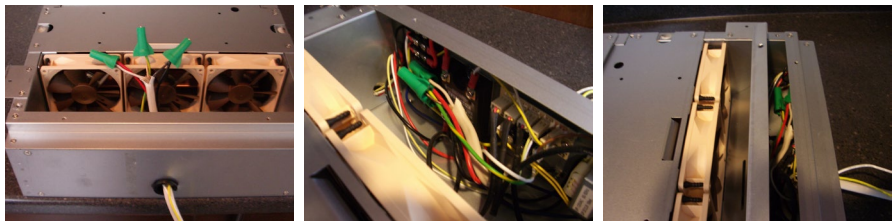

Typical wiring procedure using conventional 12/2 wire on a large heater.

Thermostat Wiring

The heater is equipped with micro-voltage thermostat leads. Any low-voltage micro or milliamp thermostat will operate the two thermostat wires. No voltage is required to the leads and no external power supply is needed.

The thermostat should be located at least 5 feet from the heater.

Wiring Diagrams

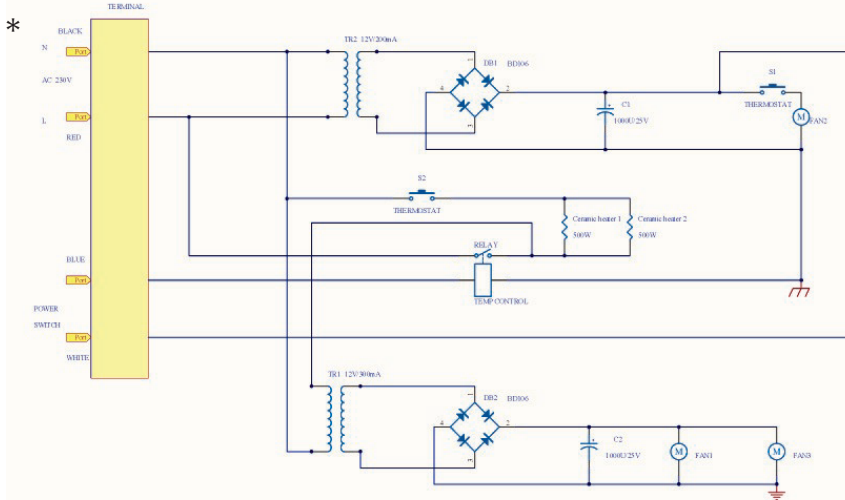

BIO-1000F/120v Wiring Schematic

* Switch must have a contact separation in all poles that provide full disconnection with a contact separation of at least 3 mm and rated 10A minimum.

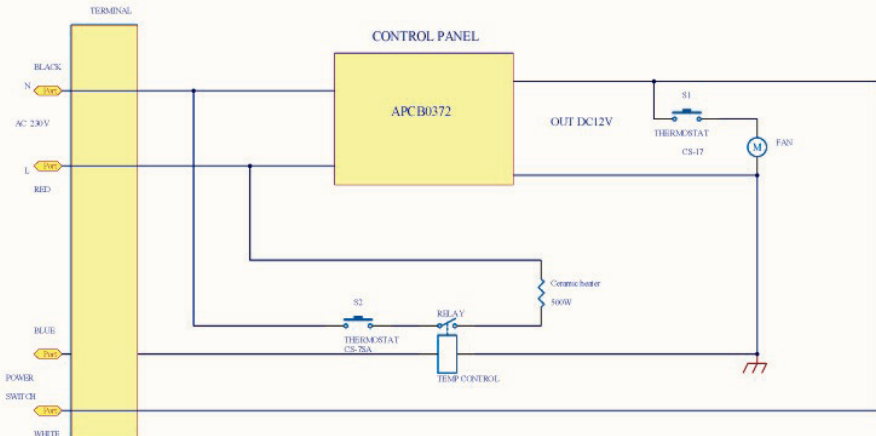

BIO-500F/120v Wiring Schematic

For Your Safety/Warning

Do not place objects in front of infrared wall units that have been mounted lower than those parameters suggested in the installation instructions. Doing so will cause the unit to overheat, which will trigger the high temperature limit switch, resulting in a potential service call to reset/replace the switch.

For Best Performance

It is recommended that the air flow pattern in the room becomes circular. This is accomplished by mounting the heater to one side of the room, as per the illustration, in order to create a circular flow around the room.

Where multiple units are installed in larger rooms, this circular pattern can be maintained by positioning the units to complement the air flows. This is accomplished by positioning them in opposite corners of the room.

Operating Instructions

The units are self-regulating. Temperature is controlled via a thermostat located preferably on the opposite wall from the heating unit. The heater fans will turn on when the power to the infrared heating elements turn on. After the heating elements have come up to full temperature, a third fan will turn on to increase the airflow into the room. This third fan will remain running even after the heating elements have been shut down by the thermostat, in order to distribute the remaining heat in the heating elements into the room.

Temperatures can be regulated from a central control (sold separately) or the heating units can also be independently turned on or off from a remote location via a central on/off switch for each unit. The switch is connected between the low-voltage thermostat control and one of the lead wires to the thermostat from the thermostat contact on the heater.

Maintenance

Routinely inspect the air registers on the infrared unit to make sure that there is no dust accumulation. Vacuum as you would any conventional heat or air conditioning duct.

It is suggested that an annual dusting of the ceramic plates be performed in order to eliminate any residual accumulation of dust during the summer months. Other than this, there are no maintenance requirements involved. In order to accomplish this, the front plastic panel must be removed by removing the four screws and lifting up to release the panel from the top clip.

Troubleshooting Your BioSmart® Heater

Problem	Solution
Heater's airflow is reduced.	Check for any objects that could obstruct airflow. If the heater's airflow is still diminished or has stopped, please call Customer Service.
Heater fan still on 20 minutes after shut-down.	This is most likely a defective fan relay. Please call Customer Service.
Heater will not turn on.	First, push the reset button. Next, check the thermostat leads. Short the leads out and if the heater turns on you have a defective thermostat, otherwise you have a defective relay in the heater. Call a service technician for installation of a new relay.
Heater doesn't seem to be getting hot enough.	Most likely, one of the ceramic elements is burnt out or the connection to the element is bad. Call Customer Service for help, the defective ceramic plate may need replacing.
Heater does not heat-up	First, push the reset button. Next, check the thermostat leads & listen to determine if the first fan is operating. If so, call a service technician for installation of a new heat relay.
The heater is noisy.	Check for obstructions to the fan blades. If there are none, you have a defective fan. Please call Customer Service.

BioSmart® 1000F In-Wall Heater Specifications

Model BIO-1000F

- **Cabinet:** All metal - 22 & 24 gauge with synthetic, paintable shell
- **Weight:** 13 lbs
- **Dimensions:** 16" x 12 5/8" x 4" (HxWxD)
- **Power Requirements:** 120 or 220 volt AC
- **Power Consumption:** 12.5A @ 120 volt, 6.75A @ 220 volt, 1500 watt
- **Chassis Safety Insulation:** Exceeds all government and independent laboratory standards for safety in an installed heating appliance (a safety standard that exceeds other manufacturer's specifications).
- **Internal Ceramic Blanket:** Provides R45 insulation between the wall and the heater. The heater cabinet remains cool to the touch while delivering warm (105° C) far infrared heat into the room.
- **Thermostat Type:** Any standard digital, programmable or mechanical (no in line high voltage)
- **Safety Cut-Off:** Prevents damage to the unit
- **Life Expectancy:** 25+ Years
- **Zoned Heat Capability:** Pre-wired - simple two-wire contact to any zone control panel
- **Heat Type:** therapeutic far infrared heat
- **Heat Chamber:** Copper-lined for maximum ion transfer
- **Heating Elements:** 2 -500 watt ceramic far infrared emitters
- **Infrared Emitter Life Expectancy:** 40,000 hours
- **Heat Output:** 4,800 BTU infrared heat
- **Fan System:** 3 high volume, low noise 90mm DC Fans
- **Fan Noise Level:** 18 dB - practically silent
- **Listed Approvals:** C-TUV-US (International UL Equivalent)
- **Warranty:** 5-Year limited



BIO-1000F

BioSmart® 500F In-Wall Heater

Specifications

Model BIO-1000F

- **Cabinet:** All metal - 22 & 24 gauge with synthetic, paintable shell
- **Weight:** 8 lbs
- **Dimensions:** 20 1/2" x 4 3/4" x 4" (HxWxD)
- **Power Requirements:** 120 or 220 volt AC
- **Power Consumption:** 6.3A @ 120 volt, 3.4A @ 220 volt, 1500 watt
- **Chassis Safety Insulation:** Exceeds all government and independent laboratory standards for safety in an installed heating appliance (a safety standard that exceeds other manufacturer's specifications).
- **Internal Ceramic Blanket:** Provides R45 insulation between the wall and the heater. The heater cabinet remains cool to the touch while delivering warm (105° C) far infrared heat into the room.
- **Thermostat Type:** Any standard digital, programmable or mechanical (no in line high voltage)
- **Safety Cut-Off:** Prevents damage to the unit
- **Life Expectancy:** 25+ Years
- **Zoned Heat Capability:** Pre-wired - simple two-wire contact to any zone control panel
- **Heat Type:** therapeutic far infrared heat
- **Heat Chamber:** Copper-lined for maximum ion transfer
- **Heating Elements:** 1 -500 watt ceramic far infrared emitters
- **Infrared Emitter Life Expectancy:** 40,000 hours
- **Heat Output:** 2,800 BTU infrared heat
- **Fan System:** 1 high volume, low noise 90mm DC Fan
- **Fan Noise Level:** 38 dB
- **Listed Approvals:** C-TUV-US (International UL Equivalent)
- **Warranty:** 5-Year limited



BIO-500F

Diagram of BioSmart® 1000F In-Wall Heater

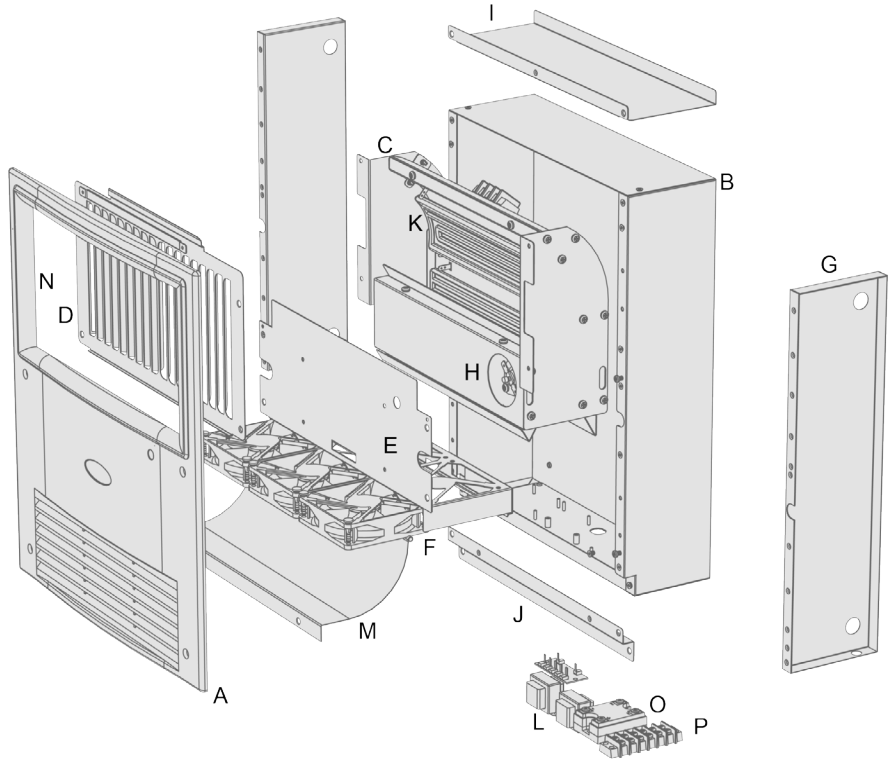

- A. Cover
- B. Case
- C. Heater Core
- D. Grill
- E. Fan Holder
- F. Fans
- G. Insulator Cover
- H. High Limit Reset
- I. Top Case Bracket
- J. Bottom Case Bracket
- K. Ceramic Heating Element
- L. PCBoard
- M. Baffle
- N. Heat Resistant Insert
- O. Solid state relay
- P. Connection Plate

Diagram of BioSmart® 500F In-Wall Heater

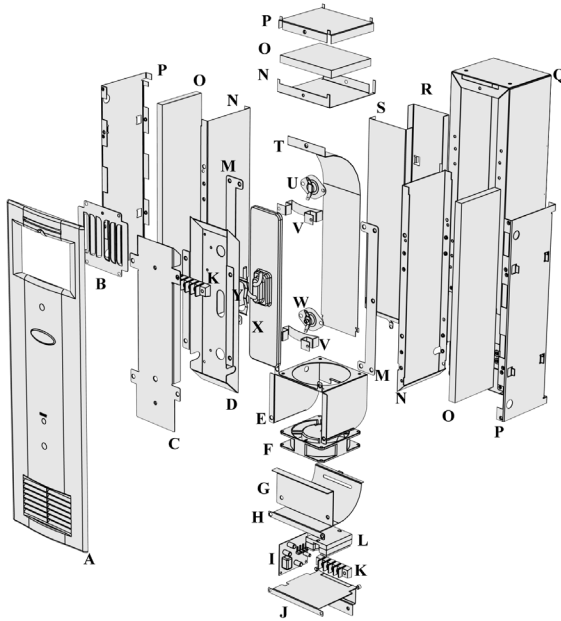

- | | |
|----------------------------------|-------------------------------|
| A. Front Cover | N. Inside Insulator Cover |
| B. Grill | O. Insulator |
| C. IR and Sensor Case Top | P. Outside Insulator Cover |
| D. IR and Sensor Case Bottom | Q. Case |
| E. Fan Case | R. Rear Baffle - Bottom |
| F. Fan | S. Rear Baffle - Top |
| G. Bottom Cover | T. Copper Air Guide |
| H. Bottom Air Guide | U. Fan Sensor |
| I. PC Board | V. IR Retaining Clip |
| J. Electrical Components Divider | W. High Heat Sensor |
| K. Connection Plate | X. Ceramic IR Heating Element |
| L. Solid State Relay | Y. IR Spacer Clip |
| M. Mounting Bracket | |

Warranty & Service Information

Five-Year Limited Warranty

BIOSMART TECHNOLOGIES (BT) warrants this product, to the original purchaser or gift recipient, to be free from defects in workmanship and materials under normal use and service, for a period of one year from the date of purchase. BT further warrants the infrared heating elements and fan motors, to the original purchaser or gift recipient, for a period of four additional years from the date of purchase.

Extended Warranty Details: For an additional four-year period, BT shall warrant the infrared elements and fan motors in the heater to be free from defects in workmanship and materials under normal use and service, and shall supply at no cost, excluding shipping, to the original purchaser replacement elements or fans as required to maintain product in good working order. Limitations on labor: During the first year of the warranty, BT will reimburse the customer \$30 for in home contractor service or 100% of labor cost provided that the defective unit is shipped back to BT for service.

Shipping: BT or its Dealer shall bear the cost of return shipping and repair, or replacement if, during the first 90 days, there is a defect in workmanship or materials. Thereafter customer shall bear the cost of return shipping to BT or repair the unit in home per the above terms for labor reimbursement. If BT receives the unit for repair, defective parts, including all labor, will be provided by BT for a period of 1 full year from the date of purchase.

Limitations

ALL WARRANTIES IMPLIED BY LAW, INCLUDING THE IMPLIED WARRANTIES OF MERCHANTABILITY AND FITNESS FOR A PARTICULAR PURPOSE, ARE EXPRESSLY LIMITED TO THE DURATION OF THE WARRANTY SET FORTH ABOVE.

Some jurisdictions do not allow limitations on the length of the implied warranty, so the above limitation may not apply to you.

Warranty & Service Information (continued)

IN NO EVENT SHALL BT BE LIABLE FOR ANY INCIDENTAL OR CONSEQUENTIAL DAMAGES, LOSS OF PROFIT, OR MEDICAL EXPENSES CAUSED BY ANY DEFECT, FAILURE, MISUSE, OR MALFUNCTION OF THE PRODUCT.

Note: Some jurisdictions do not allow the exclusion of limitation of incidental or consequential damages, so the above limitation or exclusion may not apply to you. The Company will not be responsible for the damages or losses, direct or indirect, caused by misuse, abuse, accident, negligence, conditions of transportation or storage, or failure to follow instructions.

The Company will not be responsible for any statements that are made or published, written or oral, that are inconsistent with this written warranty, or which are misleading or inconsistent with the facts as published in the literature or specifications by the Company.

Warranty Restriction

This warranty is invalid if the factory-applied serial number has been altered or removed from the product.

Warranty Claim Procedure

To obtain warranty service, you must:

1. Contact the Dealer you purchased your equipment from for additional instruction.
2. Provide proof of purchase, if requested, in the form of a Bill of Sale or receipted invoice to show evidence that the unit is within the warranty period.

*Bio Smart® Far Infrared Heaters
Green Technology for a Modern World*

North American Distribution and Sales

Bio Smart Technologies

18324 Cook Road, Suite 1
Yelm, Washington 98597

Customer/Warranty Service:
800-595-9605

Bio Smart® Far Infrared Heaters